

Instructions for Use

syramed[®] μ SP6000 PCA/EPCA

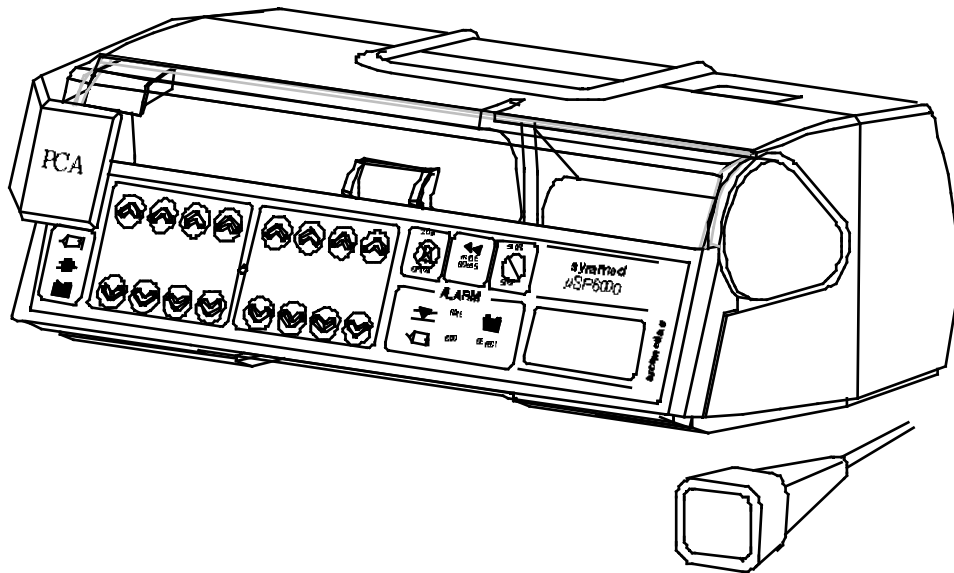

CE 0123

Swiss Made

ARCOMED AG
8105 Regensdorf / Zurich
ISO 9001 Quality Control

Edition 24/05/04 -VA-GA-6000-PCA-E

Index numbers

1	Door latch
2	Syringe clamp
3	Drive head
4	Syringe
5	ALARM SILENCE/OPTION key
6	LCD window for messages and infusion parameters
7	START/STOP key
8	PRIME/BOLUS key
9	RATE display
10	VOLUME display
11	ON/OFF key
12	RATE keys
13	VOLUME keys
14	Alarm indicators
15	Door
16	Carrying handle
17	Power and running indicators
18	Mains power connector
19	Mains fuse
20	Nurse call connector
21	IR interface
22	Pole clamp
23	Key lock PCA
24	Patient button PCA

CONTENTS

Specific PCA functions and specifications for PCA pump page 1-8.

General Description		Page
1	Introduction	see also GA-6000, 1
1.1	Mounting the pump	see also GA-6000, 1
1.2.1	Cleaning and disinfection	see also GA-6000, 2
1.2.2	Annual safety check	see also GA-6000, 2
1.3	Key to symbols	see also GA-6000, 2
2	Specifications	see also GA-6000, 3
3	Operation	see also GA-6000, 4 - 9
3.18.	Using the pump in parallel or multiple infusions	see also GA-6000, 9
4	Alarm system	see also GA-6000, 10 - 12
5.	Warranty	see also GA-6000, 12
5.1	Design changes	see also GA-6000, 12
6	Safety checks	see also GA-6000, 13
7	Performance data	see also GA-6000, 14

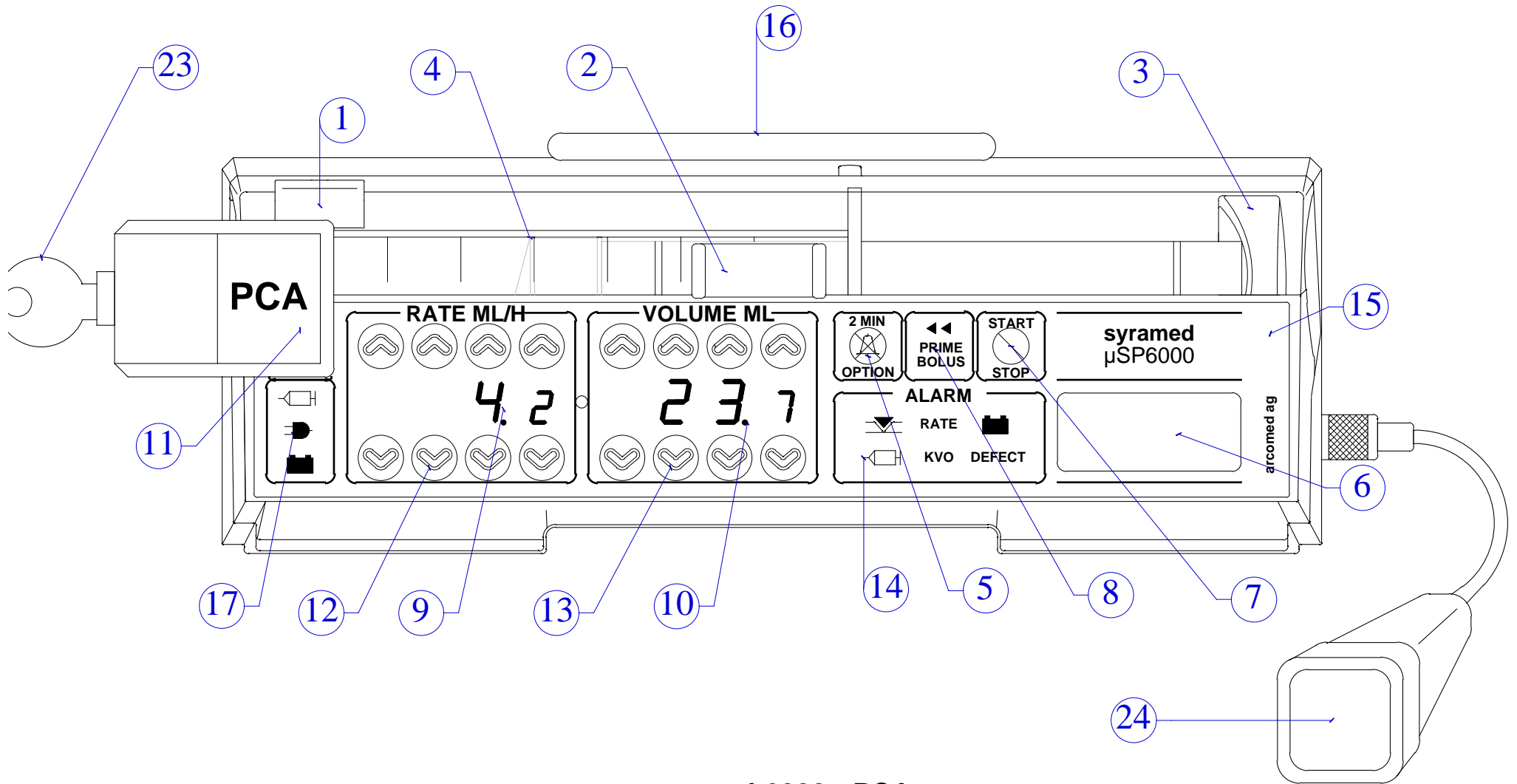

syramed 6000 - PCA
Front

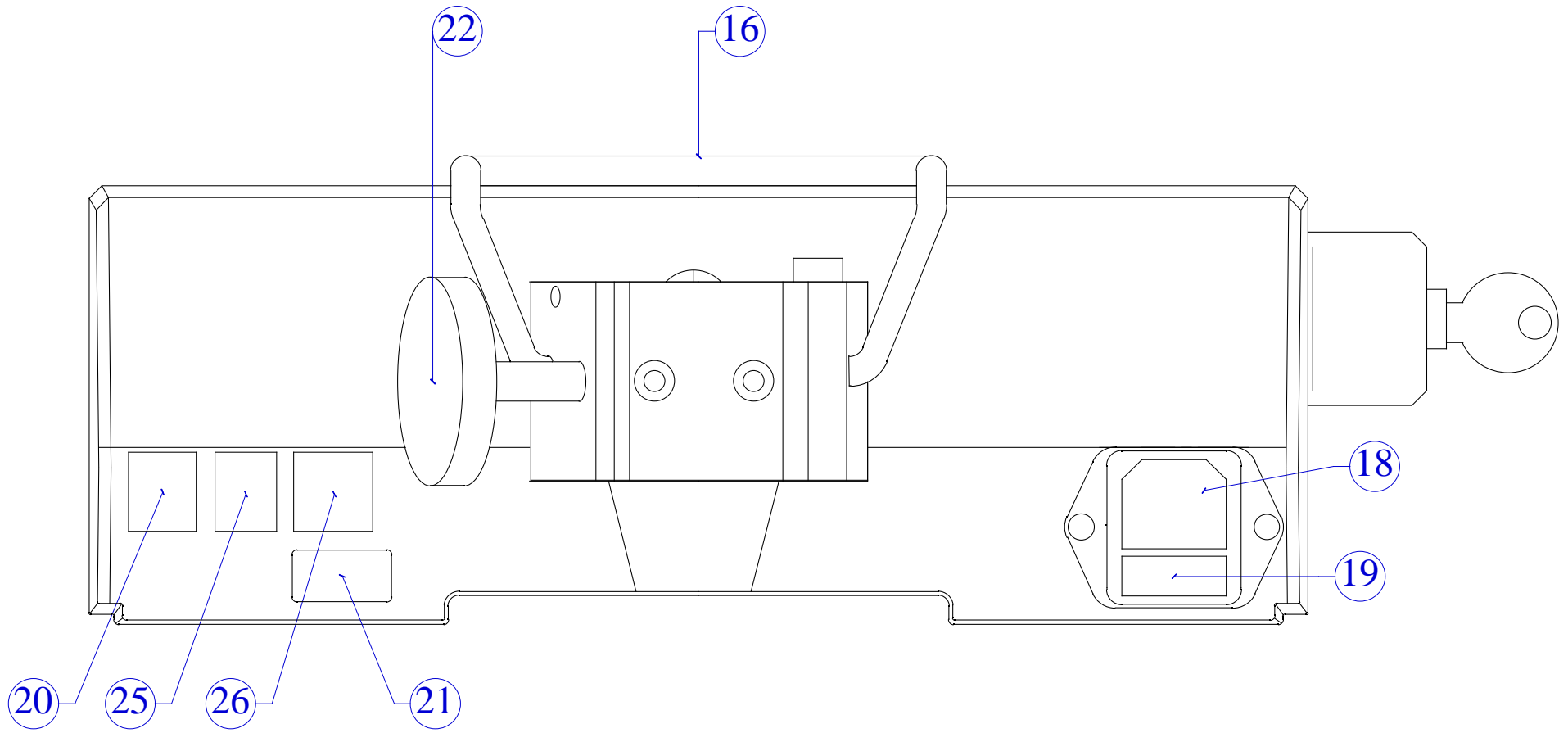

syramed μ SP6000-PCA
Rear

Syramed μ SP6000 PCA/EPCA Syringe Pump

General:

The syramed μ SP6000 PCA/EPCA is a specialized syringe pump for **patient controlled analgesia (PCA)** and **epidural patient controlled analgesia (EPCA)**.

For safety reasons the **door is locked mechanically** to avoid the removal of the syringe by unauthorized persons. A **software access code** protects all the settings of the pump. An **external patient bolus key** allows the patient to activate the patient bolus when required.

PCA Modes

The pump has different running modes:

-> **Patient bolus only.** The pump only delivers after pressing the patient bolus key with respect to the lockout time. If the patient bolus key is pressed during the lockout time, no bolus is delivered.



-> **Patient bolus and continuous basal rate.** A continuous basal rate is delivered during the whole administration. Additional patient bolus can be requested by pressing the patient bolus button.

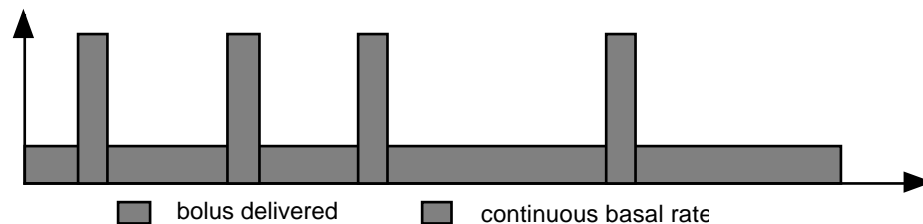

-> **Patient bolus and limited continuous basal rate.** After each bolus the pump continues to deliver for a limited time a continuous basal rate.

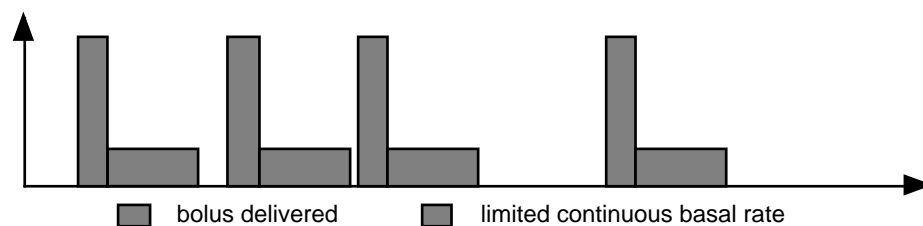

-> **Initial charge bolus.** The administration is started with an initial charge bolus. After the initial charge bolus, further patient bolus can be requested by pressing the patient bolus key with respect to the lockout time.



-> **Physician bolus.** A physician bolus can be requested at any time using the access password.



PCA Configurations

Nine configurations can be selected after start up:

- > **Individual** configuration: the individual program allows to freely program the current administration and can be adapted at a later stage of the application. The initial values are always set to zero after start up.
- > **PCA 1 ... 8:** Up to eight configurations can be freely set up and stored for later administration. After the selection of a stored configuration, the parameters can be adjusted for the current administration if needed. The values are reset to the stored configuration after the next start up. The eight stored configurations can be labeled with an alphanumeric text (12 characters) through the IR interface.

History log and traceability:

The syramed SP6000 PCA/EPCA stores an extensive history log to trace all events during an administration. Up to 1500 history logs can be stored in the pump.

The history can be viewed, stored and printed by downloading the history over the IR interface during or after the application. The history can also be viewed graphically to allow a rapid and complete overview of the administration.

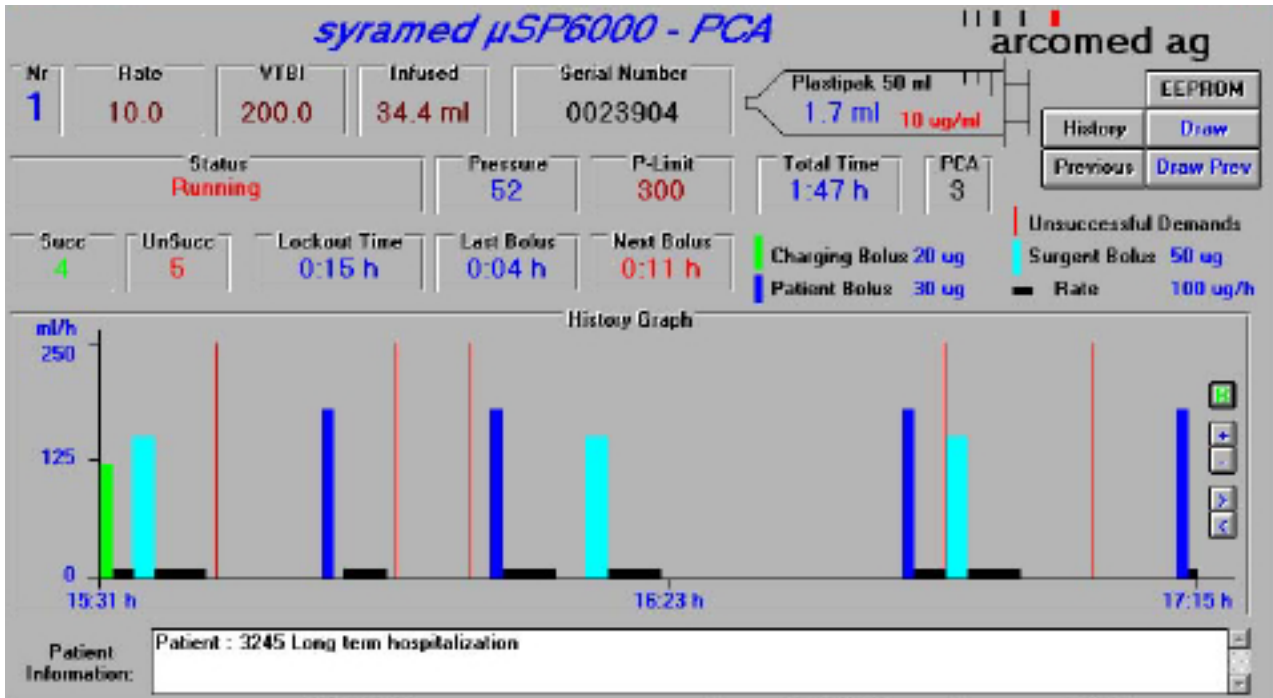

Syramed μSP6000 History File
 Date: 01/03/26, Time: 17:42:44
 Pump Serial Number: 0023904
 Patient Information:
 Patient : 3245 Long term hospitalization

- 15:53h Stop Infusion at Infused 11.2 ml.
- 15:53h Stop patient Bolus at Infused 11.1 ml.

- 15:52h Start patient Bolus at Infused 8.1 ml.
- 15:42h Unsuccessfull patient bolus at Infused 8.1 ml.
- 15:41h Halt continuous basal rate at Infused 8.1 ml.
- 15:36h Stop physician Bolus at Infused 7.3 ml.

- 15:32h Stop charge Bolus at Infused 2.0 ml.
- 15:31h Start charge Bolus at Infused 0.0 ml.
- 15:31h Current PCA setup:
 Selected PCA Program: 3
 Concentration Unit: ug
 Concentration: 10 ug
 Charge Bolus Dose: 20 ug; Charge Bolus Time: 1 min
 Patient Bolus Dose: 30 ug; Patient Bolus Time: 1 min
 Continuous basal Rate: 100 ug/h
 Continues Total: 2000 ug
 Lockout Time: 0:15 h
 Continuous basal Time: 0:05 h

The LED and LCD display on the pump show the current values and a summary of the history (current rate and volume infused, successful and unsuccessful demands, total time and dose,

Setting up the pump

- The LCD display guides through the whole set up with help comments.
- After the pump has been switched on with the ON/OFF key, the syramed automatically enters the set up mode and asks for the password.
- The pump can be configured to be used with a 4 digit password or with a supervisor key only.
- The selections and values are entered in the Volume ML window.
- To confirm a selection or value press the START/STOP key. Automatically the next step is displayed.
- To go back to a previous setting, lower the program step in the Rate ML/H window with the down key.
- All the configuration parameters have to be viewed and confirmed. After confirming the last parameter (Pr. 14: surgeon bolus time) with the START/STOP key, the syramed switches to the running mode. If the set up mode has been interrupted (e.g. by a syringe loading action), the pump will automatically re-enter the set up mode when starting the pump.

For safety reasons, the administration can only be started after all the settings have been entered and confirmed.

- The loading of the syringe is done similar to the standard syringe loading procedure of the syramed (refer to the syramed 6000 instructions for use).

How to start up the pump - Programmed modes PCA 1 - 8

- 1) Switch on the pump with the ON/OFF key.
- 2) Enter the password and press the START/STOP key or plug in the supervisor key.
- 3) Select the desired program with the up/down keys in the Total ML window.
- 4) Press the START/STOP key.
- 5) Confirm all the values (Pr. 2 - 14) with the START/STOP key until the pump switches to the running mode.
- 6) Load the syringe and start the pump with the START/STOP key.
- 7) The LCD display is showing the current status of the pump (running). The green syringe pictogram below the ON/OFF key is flashing when the pump is running.
- 8) **Make sure the door is mechanically locked.**

How to start up the pump - Individual (titration) mode

- 1) Switch on the pump with the ON/OFF key.
- 2) Enter the password and press the START/STOP key
- 3) Press the START/STOP key (confirm Individual mode).
- 4) Set all the values (Pr. 2 - 14) with the keys in the Total ML window and confirm with the START/STOP key until the pump switches to the running mode.
- 5) To disable undesired options leave the setting values at zero, eg:
 - no charge bolus -> leave the charge bolus dose at zero
 - no continuous basal rate -> leave continuous basal rate at zero
 - no limitation of continuous basal rate -> leave continuous basal time at zero
 - no total volume limitation -> leave total dose at zero

How to stop the pump

The pump can be stopped at any time by pressing the START/STOP key. If the pump is infusing a bolus (charge-, patient- or physician) the bolus is abandoned immediately. The administration can be continued by pressing the START/STOP key.

Important: An interrupted bolus is not continued after restarting the pump (safety).

How to give an initial charging bolus dose:

After start up of the pump, make sure the charge bolus dose and the charge bolus time have been set correctly. The initial charge dose is automatically administrated after starting the pump.

Important: The initial charge dose is only given once at the very first start. If the pump had been stopped with the START/STOP key, no further initial charge dose is given after restarting the administration.

How to give a patient bolus:

The patient bolus can be requested by pressing the patient bolus key. As an alternative the patient bolus can also be started by pressing the Option key and the BOLUS key simultaneously on the front panel of the pump. Each patient bolus is counted and accumulated.

After each bolus (charge-, patient- or physician) the **lockout time** is activated. During the lockout time, the patient bolus demands are rejected and counted as unsuccessful patient bolus demands.

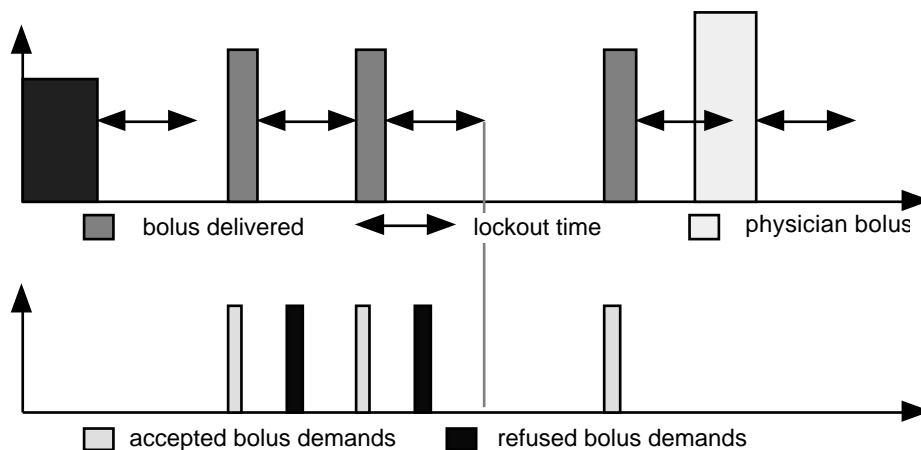

The **PCA history window** (LCD display) gives information on the timing. The time elapsed since the **last** bolus had been given is displayed as well as the remaining lockout time until the **next** patient bolus will be accepted. Furthermore the amount of successful and unsuccessful patient bolus demands are displayed in the PCA history window.

How to give a physician bolus:

The physician bolus can be requested by holding the BOLUS key on the front panel of the pump. The LCD display will ask for the password which has to be entered in the Volume ML window. Press the START/STOP key to confirm the physician bolus. The physician bolus can also be given using the supervisor key when asked for the password.

How to change the configuration

- 1) Stop the pump with the START/STOP key.
- 2) Double click the BOLUS key.
- 3) Enter the password and press the START/STOP key or plug in the supervisor key.
- 4) Press the START/STOP key and change the desired values
- 5) Press the START/STOP key until the pump switches to the running mode.
- 6) Press the START/STOP key to start the pump.

How to program and store the configuration PCA 1 - 8

- 1) Switch on the pump with the ON/OFF key.
- 2) Enter the password and press the START/STOP key or plug in the supervisor key.
- 3) Select the desired program with the up/down keys in the Total ML window.
- 4) Press the START/STOP key.
- 5) Set all the values (Pr. 2 - 14) with the keys in the Total ML window and confirm with the START/STOP key until the pump switches to the running mode.
- 6) Hold the OPTION key when switching off the pump with the ON/OFF key (save).
- 7) Repeat this procedure for each configuration

The configurations PCA7 & 8 are quick access configurations that do display only a limited number of parameters. To view and set all parameters press the Prime Key at start up.

How to continue a PCA administration (memory key)

If the syramed has been switched off, the PCA administration can be continued by recalling all the values at start up:

- 1) Hold the START/STOP key (5 sec) while switching on the pump with the ON/OFF key. The pump will go through the display test.
- 2) Enter the password and press the START/STOP key or plug in the supervisor key.
- 3) Confirm all the values (Pr. 2 - 14) with the START/STOP key until the pump switches to the running mode.
- 4) Press the START/STOP key to continue the administration.

How to start a new PCA administration

To start a new PCA administration, switch off the pump. After switching on the pump, all the values will be reset to zero.

Specifications:

Continuous rate:	0.1 ml/h - 500 ml/h (759 ml/h), 0.1 mg/h - 999.9 mg/h, 1 µg/h - 9999 µg/h
Maximum bolus rate:	1500 ml/h
Maximum dose:	0.1 ml - 999.9 ml, 0.1 mg - 999.9 mg, 1 µg - 9999 µg
Unit:	ml, mg/ml or µg/ml
Concentration:	1 (unit = ml), 0.1 mg/ml - 100.0 mg/ml, 1 - 1000 µg/ml
Charge bolus dose:	0.1 ml - 100.0 ml, 0.1 - 100.0 mg, 1 - 1000 µg
Charge bolus time:	Flash or 1 - 100 min
Patient bolus dose:	0.1 ml - 100.0 ml, 0.1 - 100.0 mg, 1 - 1000 µg
Patient bolus time:	Flash or 1 - 100 min
Lockout time:	1 min - 24:00 h
Physician bolus dose:	0.1 ml - 100.0 ml, 0.1 - 100.0 mg, 1 - 1000 µg
Physician bolus time:	Flash or 1 - 100 min
Continuous basal time:	1 min - 24:00 h
Maximum time:	1 min - 72:00 h
PCA Modes	Bolus only, Bolus and continuous basal rate, Bolus and limited continuous basal rate
Configurations	1 Individual (titration) and 8 programmed
Configuration labeling	12 characters for each programmed configuration. Programming through the IR Interface.
History log	up to 1500 events, all events and current configuration with real time clock. Read out of the history through the IR interface.

File Name:

1ml/h Monoject 50ml

∅ Flow (2nd h):

0.984

∅ Error[%] (2nd h):

0.505

Rec. date:

20.7.2001

Rec. time:

17:51:26 Uhr

Rate (ml/h):

1.0

Evaporation:

0.02

Scans:

240

Interval (s):

30

Flow [ml/h]:

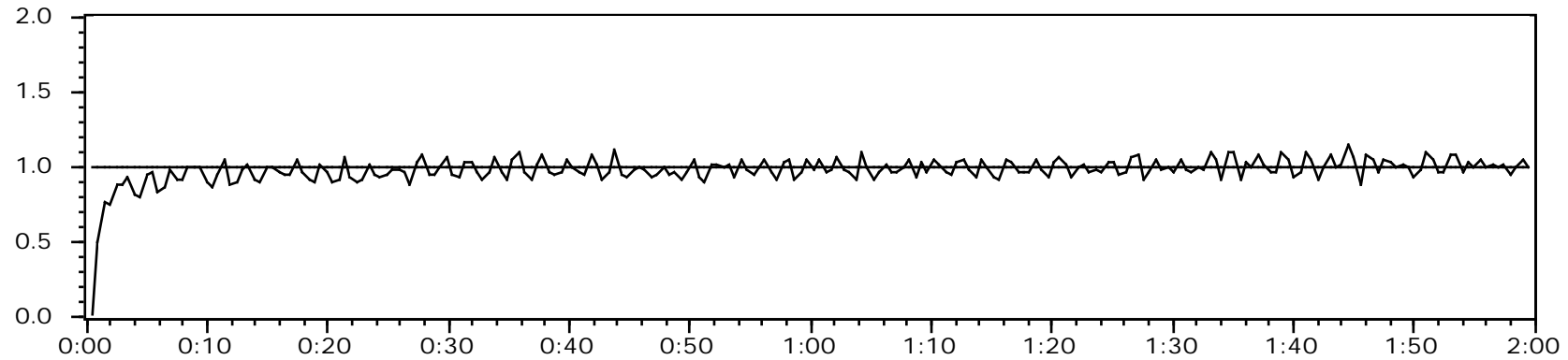

Trumpet Curve (2nd h):

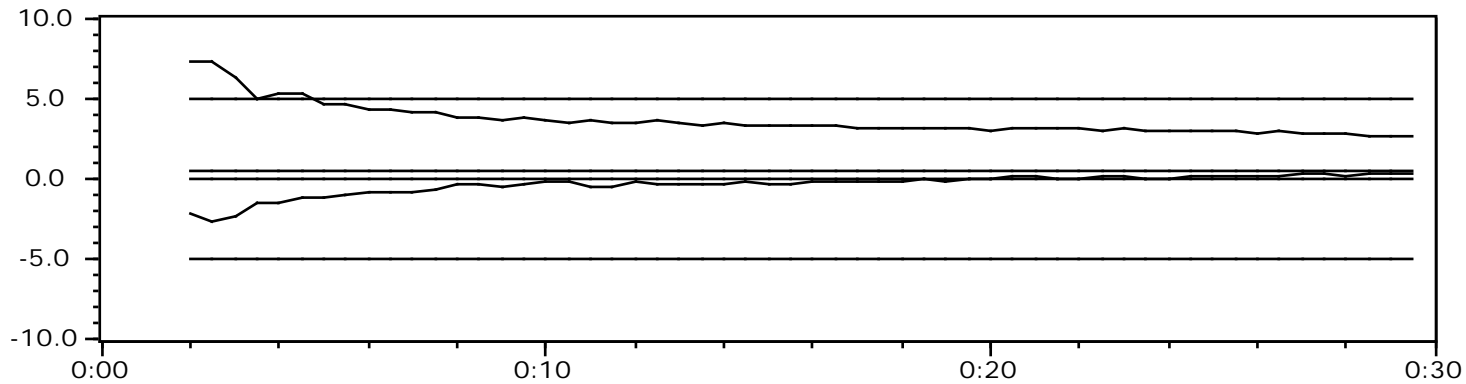

2 Min (max):

6.85

2 Min (min):

-2.65

5 Min (max):

4.27

5 Min (min):

-1.61

File Name:

5 ml/h BD Plastipak (IEC)

∅ Flow (2nd h):

4.983

∅ Error[%] (2nd h):

-0.322

Rec. date:

31.7.2001

Rec. time:

12:32:44 Uhr

Rate (ml/h):

5.0

Evaporation:

0.00

Scans:

240

Interval (s):

30

Flow [ml/h]:

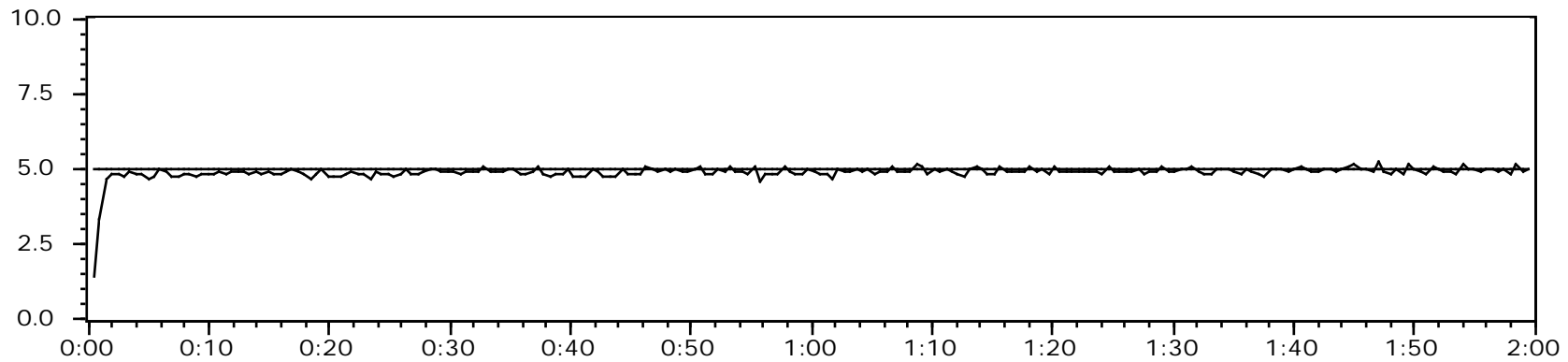

Trumpet Curve (2nd h):

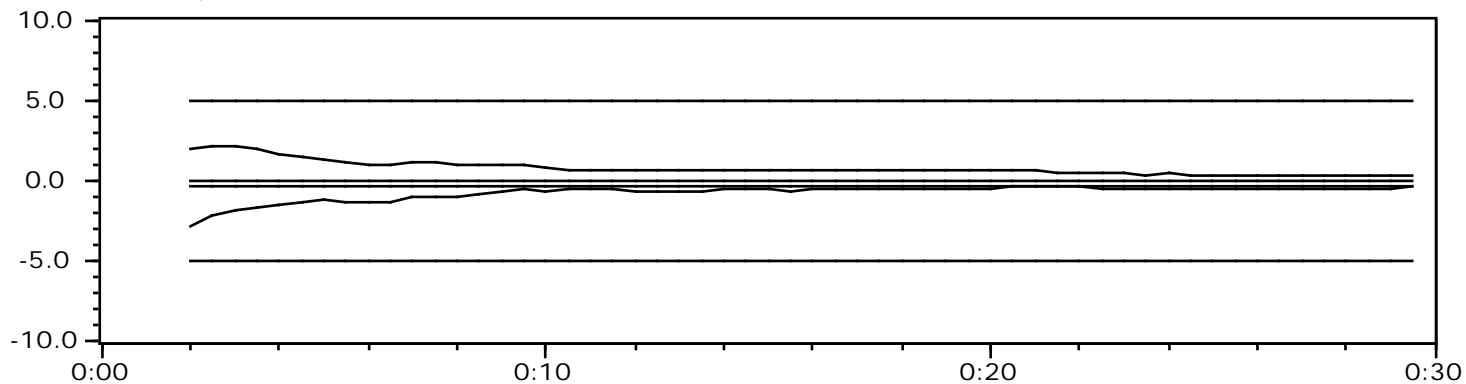

2 Min (max):

2.34

2 Min (min):

-2.46

5 Min (max):

1.80

5 Min (min):

-0.83

File Name:

Syramed PCA (ug)

∅ Flow:

--

∅ Error[%]:

--

Rec. date:

13.7.2001

Rec. time:

11:51:45 Uhr

Rate (ml/h):

50.0

Evaporation:

0.00

Scans:

1800

Interval (s):

4

Flow [ml/h]:

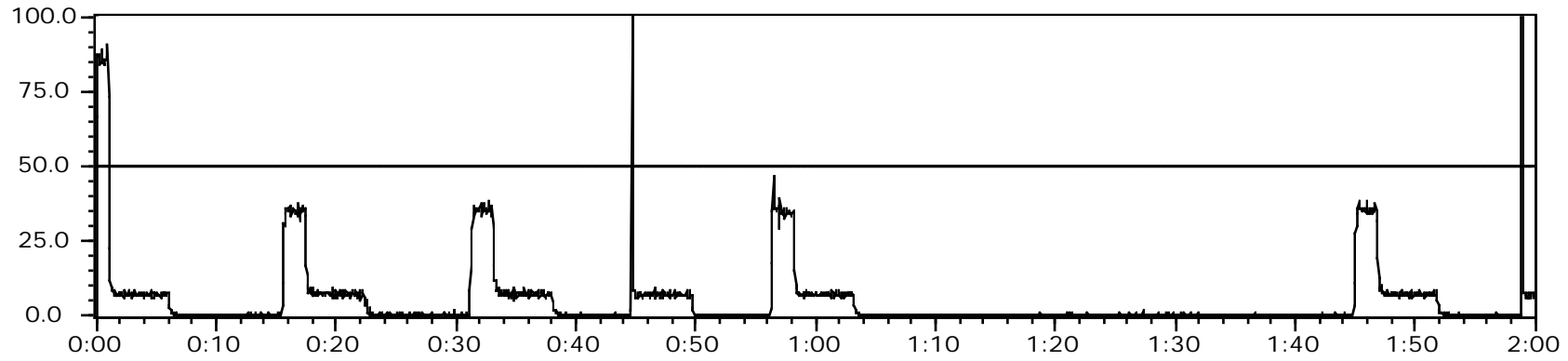

Volume [ml]:

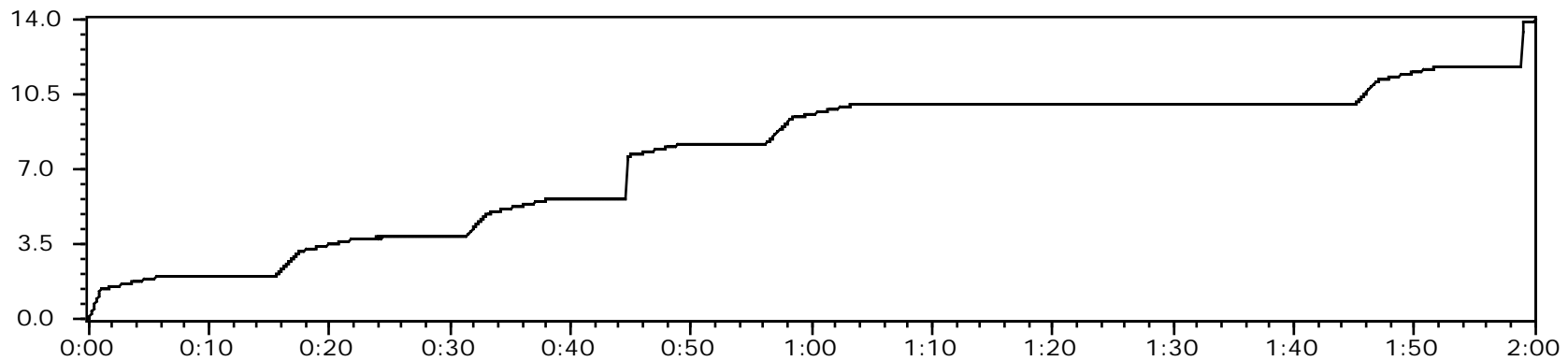

CONTENTS

		Page
1	Introduction	1
1.1	Mounting the pump	1
1.2.1	Cleaning and disinfection	2
1.2.2	Annual safety check	2
1.3	Key to symbols	2
2	Specifications	3
3	Operation	4 - 9
3.18.	Using the pump in parallel or multiple infusions	9
4	Alarm system	10 - 12
5.	Warranty	12
5.1	Design changes	12
6	Safety checks	13
7	Performance data	14

Index numbers

1	Door latch
2	Syringe clamp
3	Drive head
4	Syringe
5	ALARM SILENCE/OPTION key
6	LCD window for messages and infusion parameters
7	START/STOP key
8	PRIME/BOLUS key
9	RATE display
10	VOLUME display
11	ON/OFF key
12	RATE keys
13	VOLUME keys
14	Alarm indicators
15	Door
16	Carrying handle
17	Power and running indicators
18	Mains power connector
19	Mains fuse
20	Nurse call connector
21	IR interface
22	Pole clamp

1. Introduction

1.0 Introduction

The Syramed μ SP6000 is a syringe pump using the latest technology. This microprocessor-controlled syringe pump operates by pumping the infusate in the syringe using a controlled single action pumping stroke. The sterility of the infusate is not affected. The pump is designed to infuse drugs or other infusates into the patient by controlled means under pressure.

The Syramed μ SP6000 meets the performance requirements of the MDA (UK) for neonatal and high risk infusions. It can be used in both stationary and transportable applications as it has a long battery life up to 12 hours duration. Applications include neonatology, intensive and cardiac care, paediatrics, gynaecology and obstetrics, surgery and general medicine. It can also be used in ambulances and air rescue. It is not recommended for blood infusion (unless the dose requirement is small) due to the limitations in syringe size accommodated (50/60ml maximum).

The Syramed μ SP6000 meets the Medical Device Directive (MDD) requirements of the EC Guideline 93/42 EEC and is marked CE 0123 (TUV PS Munich, Germany).

The manufacturer according to MDD is Arcomed AG, Althardstrasse 146, CH 8105 Regensdorf, Zurich, Switzerland. Responsible for the EC is Arcomedical Infusion Ltd., West Horndon, Essex CM13 3XL, UK.

The Syramed μ SP6000 may be operated only on mains power installed to DIN 57107 VDE 0107 or the appropriate national standards. If the integrity of the mains power supply protective earth system is in doubt, the pump should be operated on battery power. Mobile telephones should not be used anywhere near this equipment.

1.1 Mounting the pump

Check the pump and accompanying accessories for damage when unpacking. The pump must not be operated if damaged. Should the pump be damaged contact our Service Department.

Permitted mounting: positioned on a flat horizontal surface or pole mounted on an infusion stand or rail mounted.

The pump should normally be operated from a mains power supply. The internal batteries will automatically operate the pump in the event of a power failure.

CAUTION: This pump is not designed for use in areas where there is an explosion hazard. Environmental requirements as per IEC601-1-2 must be observed. Do not operate this pump in an environment with high levels of electromagnetic radiation such as surgical diathermy or mobile telephones. For further information contact the official distributor in your country or the Customer Service Department in Switzerland:

Switzerland: a r c o m e d a g, Althardstr. 146, CH-8105 Regensdorf
Tel. ++41 (0)43 388 90 30, Fax. ++41 (0)43 388 90 40

United Kingdom: Arcomedical Infusion Ltd., 5j West Horndon Industrial
Estate, West Horndon, Essex CM13 3XL, UK
Tel. ++44 (1) 277'81'04'32 Fax. ++44 (1) 277'81'19'67

1.2.1 Cleaning and disinfection

CAUTION: The pump must be switched off and disconnected from the mains power supply before cleaning and disinfecting.

The pump must be kept clean and dry. Remove any spillage immediately. The pump must not be placed in an autoclave.

The unit is disinfected by wiping over with a cloth which has been dampened slightly with an alcohol-based disinfectant. Take care when cleaning that no liquid enters the inside of the pump case. Wait at least 30 seconds after disinfecting before switching the pump on. Use only disinfectant that are compliant with:

- **ABS, POM, stainless steel, PVC, aluminum, silicone**

Please check with your supplier of disinfectant.

1.2.2 Annual safety check

Battery power is provided by a nickel metal hydride (NiMH) battery which must be checked annually. Battery condition is checked by connecting the pump to the mains power supply for 15 hours in a switched off condition so that the battery may be fully charged. Disconnect the mains power supply and switch the pump on using battery power. Determine the operating time when the low battery alarm activates. This should be at least 3 hours - if not the battery must be replaced. Repeated charging and discharging may in certain circumstances cause degeneration of the battery (memory effect).

Used batteries must be disposed of in an environmentally friendly manner or returned to the manufacturer.

Safety checks (see chapter 6) may be performed only by qualified staff.

1.3. Key to symbols

The pictograms and symbols shown on the reverse of the pump have the following meanings or functions:



Nurse call

IR

Interface RS232
(Infrared)



CF (cardiac floating) part



CAUTION: consult accompanying documents

IPX 1

Drip-proof



class II double insulated

2. Specifications

CE Marking	No. G5 01 08 13006 010
Classification	IIb
Software revision	1.xx
Flow rate range (ml/h)	0.1 - 500 (750 max)
Flow rate increments (ml/h)	0.1
Volume range (ml)	0.1 - 999.9
Volume increments (ml)	0.1
Syringe size (ml)	5, 10, 20, 30, 50/60 (Automatic size recognition)
Syringe brands	B Braun, Fresenius, BD, Monoject, Terumo, Codan, other brands on request
Syringe nearly empty alarm	3 mins (adjustable)
Bolus volume after occlusion	Automatic bolus reduction (see also 3.9)
Overinfusion in case of electrical or mechanical defect	1.5 ml max.
Keep vein open rate (KVO)	0.3 ml/h, adjustable
Bolus rate, Prime rate	1500 ml/h (50/60 ml syringe), adjustable
Alarm pressure limit	0 - 999 mbar/mmHg
Battery operation time (1.85Ah)	3 - 12 hours (dependent on rate set)
Charging time	15 hours/20 hours
Supply voltage	230 VAC+10%-15%, 50/60 Hz
External power supply (optional)	12-15V AD/DC
Input power	8.5 VA
Mains fuse	T200 mA
Type of protection against electric shock	Class II
Protection against ingress of liquids	IPX 1, drip proof
Leakage current	< 40µA
Radio interference	CE-Class A
Nurse call, potential-free contact switch	24V/0.2A
Degree of protection against electric shock	CF (cardiac floating)
Dimensions	245x90x180 mm (WxHxD)
Housing	ABS plastic, UL listed
Weight	2.3 kg (approx.)
Max. storage period	3 months without charging
Permitted temperature range (operation/storage)	15°C - 35°C / 0°C- 40°C
Permitted relative humidity	20-90% max. (no vapor deposit)
Safety certification	DIN IEC 601 Part 1 EN55011 Radio interference IEC601-1-2 Susceptibility IEC601-2-24

3. Operation

The figures in brackets refer to the illustrations of front and rear views shown in the appendices.

CAUTION: Use only approved disposable syringes!
Only use syringes with Luer lock fitting

The pump may be configured for one or several brands of disposable syringe:

B. Braun, Fresenius, Becton Dickinson, Monoject, Terumo.

Permitted syringe sizes:

5, 10, 20, 30 and 50/60 ml. The size is identified automatically by the pump.

The functional safety of the pump cannot be guaranteed if non-approved syringes are used. The safety of the patient may be compromised as a result.

Disposable syringes are for single-use only. Single-use needles carry an infection hazard and must be disposed of in accordance with local guidelines. Remark: To avoid air infusion, air filters can be used as there is no obligation to have an air in line detector on syringe pumps.

Important:

- The patient must be disconnected during the loading and the removal or change of the syringe.
- The user must check that the pump and drive is not damaged and that the syringe plunger latch is in its home position before loading the syringe. In case of damage the syringe must not be used.
- The syringe must not be placed more than 50 cm above the patient and negative pressures must be avoided.
- In case of multiple or parallel infusions high pressures or negative pressures can influence the accuracy of the rate (see also 3.18). In the case of strong negative pressure siphoning can occur and the plunger can be pulled with considerable forces. It is important to know that these forces can also pull the plunger after the syringe latch is opened and the pump is not in control of the syringe.

3.1. Preparation and loading of syringe

- a) If the pump is to be operated on an infusion stand, care must be taken that the pump is not positioned more than 1.4m above the ground to ensure stability. Ideally use an "Arco Luxe" or "Arco Standard" infusion stand. If several pumps are mounted one above the other the maximum permitted height from the floor must be observed and measures taken to prevent instability.
- b) The pump may be fixed to the infusion stand by means of the pole clamp (22) on the rear of the unit.
- c) Where possible mains power should be used. Plug the mains power cable into the connector socket (18) at the rear of the pump. The mains pictogram illuminates as soon as the mains supply is connected. The battery is charged automatically.
- d) Draw up the infusate into the syringe using an aseptic technique and make sure there is sufficient excess volume to prime the extension set. Connect the

extension set.

- e) Press the ON/OFF key (11). The audible alarm beeps and all indicators illuminate. The software revision number (rx.xx) and then the pump configuration (C.xxx) illuminate briefly.
- f) Open the pump door (15) by releasing the latch (1). Open the syringe clamp (2). The drive head (3) is powered automatically to extend fully to the right.
- g) Locate the syringe (4) in the pump with the Luer connector to the left so that the ears of the syringe are positioned in the slot in the pump body. **THIS IS IMPORTANT.** Push the syringe ears to the left so that they engage the front edge of the slot.

Controlled automatic syringe loading:

After closing the syringe clamp (2) the drive head stays extended to the right. Press the PRIME key (8) and hold it down so that the drive head is powered to engage the syringe and to lock onto the syringe plunger. When the infusion is finished press the PRIME key (8) to move the drive head to the parking position.

CAUTION

During the loading process, the user must check that infusion lines electrode leads or any other obstructions do not get caught up in the drive system and that the syringe plunger latch is in its correct home position to allow a correct syringe loading. Check that the plunger is correctly secured after loading.

- h) The LCD window (6) indicates the brand and size of syringe. Press the START/STOP key (7) to confirm this. If the pump is configured for several syringe brands, the OPTION key (5) must be pressed sequentially to select the brand. When the correct brand is displayed, press the START/STOP key (7) to confirm.
- i) The LCD window now indicates "purge". Press and hold the PRIME/BOLUS key (8) to prime the extension set. For safety reasons connect the patient only after correct loading and purging of the syringe.

3.2. Setting rate (ml/h) and volume (ml)

Use the UP/DOWN keys (12) to select the required rate in ml/h indicated in the RATE display (9). Arrow up keys provide rate increase, arrow down keys provide rate decrease. Check that each key stroke changes one digit. The least significant digit (small size) indicates 0.1 (units).

If the full volume of the syringe is to be infused, make the patient connection and press the START key (7) to commence the infusion.

If a specific volume is to be infused, the required volume in mls may be selected in the VOLUME window (10) using the UP/DOWN keys (13) before starting the pump.

3.3. Pump running

When the pump is running, the green syringe symbol flashes. The VOLUME display now indicates the volume infused in mls. In order to display various data, such as pump condition, volume to be infused, infusion time, time to end of infusion, battery condition, syringe brand and size, pressure and pressure limit, press the OPTION key (5) sequentially and observe the LCD window (6) until the required data is displayed.

If a specific volume to be infused was selected the pump automatically switches

to KVO operation when this volume has been infused and an audible and visual alarm (14) activates.

The near end of syringe alarm activates three minutes before the syringe is empty (audible and visual warning). The time before end of syringe may be adjusted (by a technician) as required. Press the ALARM SILENCE key (5) to silence the audible alarm for 2 minutes.

3.4. Resetting the volume infused

In order to reset the volume infused, stop the pump by pressing the STOP key (7). Press the OPTION key (5) for 2 seconds until the VOLUME display (10) flashes. When the LCD window (6) displays "000", confirm this by pressing the START/STOP key (7) to reset the volume infused to zero. If it is not desired to reset the volume infused, press the OPTION key (5) until the normal display appears.

3.5. Infusing a bolus

When the pump is infusing, a manual or an automatic bolus can be given.

To infuse a manual bolus:

Press the OPTION key (5) and the BOLUS key (8) together.

The bolus rate is displayed in the RATE window (9) and the bolus volume infused is displayed in the VOLUME window (10). The LCD window (6) indicates "Bolus manual". Keep the keys depressed until the required bolus volume has been infused. As soon as the keys are released the pump reverts to the normal infusion mode.

To infuse an automatic bolus:

Press the Bolus key (8) for 2 seconds until the display in the VOLUME window (10) flashes. The desired bolus volume in mls can then be preset in the VOLUME display using the VOLUME keys (13). Press the BOLUS key (8) to deliver the bolus automatically. If no bolus is required, press the OPTION key (5) to cancel.

During automatic bolus delivery, the RATE display (9) indicates the bolus rate and the VOLUME display (10) indicates the bolus volume infused. The LCD window (6) indicates "Bolus automatic".

To stop the pump at any time press the STOP key (7).

After the selected bolus volume has been delivered, the pump switches automatically to normal delivery mode.

Following bolus infusion, the bolus volume is added to the total ml infused.

3.6. Removing or changing a syringe

Press the START/STOP key (7) to stop the pump. Open the door (15) and open the syringe clamp (2). The syringe plunger unlocks automatically and the drive head (3) extends fully to the right.

If a new syringe is to be fitted to continue the infusion, it can be loaded as in section 3.1 without switching the pump off. Rate, volume to be infused and volume infused data are stored.

3.7. Recall of previous data

If the pump has been accidentally switched off, data such as rate, volume to be infused and volume infused may be recalled during start up. Press the START/STOP key (7) and the ON/OFF key (11) together to recall all data.

3.8. Setting volume and time

If a specific volume is to be infused in a given time the RATE display must be left at zero. When the syringe has been primed, press the START/STOP key (7) to confirm. Then press and hold the OPTION key (5) until the RATE and VOLUME displays flash. The time in hours and minutes may be selected in the RATE display (9) and the volume selected in the VOLUME display (10). The pump automatically calculates the infusion rate. Check this carefully in the LCD window (6) before starting the infusion.

3.9. Pressure system

The Syramed SP6000 has automatic pressure monitoring whereby the pressure in the system is measured via the syringe plunger. The alarm pressure limit can be set automatically or manually.

Automatic setting:

If the pump is configured for this mode, the alarm pressure limit is automatically matched to the set rate, the lower the rate, the lower the alarm pressure limit.

Example (Injectomat):

- 50 ml syringe, 25 ml/h, press. limit 800 mBar, Time to alarm: 160 sec.
- 10 ml syringe, 5 ml/h, press. limit 300 mBar, Time to alarm: 100 sec.

Manual setting:

Press the OPTION key (5) sequentially to display pressure and alarm pressure limit in the LCD window (6). Hold down the OPTION key (5) until the VOLUME display (10) flashes "Lxxx". The pressure limit may be manually set using the VOLUME keys (13) in the VOLUME display (10) and the data in the LCD window changes accordingly. This can also be done while the infusion is in progress.

NOTE: Manual setting of pressure deactivates the automatic pressure setting, i.e. the pressure remains at the current level independent of the rate selected.

Example (Injectomat):

- 50 ml syringe, 25 ml/h, press. limit 500 mBar, Time to alarm: 100 sec.
- 10 ml syringe, 5 ml/h, press. limit 200 mBar, Time to alarm: 70 sec.

If the pressure rises beyond the limit set, the pump stops and the stored bolus is automatically reduced to virtually zero volume. An audible and visual alarm is activated. Check the IV carefully for the cause of the alarm. Do not restart the pump until the occlusion is released.

3.10. Setting time and date

Press the OPTION key (5) sequentially to display date and time in the LCD window (6). Hold the OPTION key (5) down until the display flashes. The time may be set using the volume keys (13) in the Volume display (10), e.g. h9.45 = 9:45 am. This can also be done while the infusion is in progress.

The syramed has the possibility to automatically adjust the daylight save time (summer time). The adjustments can be done as per EU, US or Australian regulations. If the text 'Clock !' should appear, replace the Lithium backup battery on the main PCB.

To set the date, first switch the pump off. Press the VOLUME 0.1 ml DOWN and VOLUME 100 ml DOWN keys (13) together whilst switching the pump on. This enables the Service Mode. Select the RATE display (9) according to the following table using the RATE keys (12). Then select the corresponding data in the VOLUME display (10) using the VOLUME keys (13). Press the START key (7) each time to confirm each setting:

<u>Rate display (9)</u>	<u>Volume display (10)</u>	<u>Function</u>
145	0 - 99	Year
144	1 - 12	Month
143	1 - 31	Date
142	1 - 7	Weekday (Monday = 1, Sunday = 7)

Press the ON/OFF key (11) to switch the pump off.

Note: Incorrect setting of date or time does not affect the correct functioning of the pump.

3.11. Different configurations

If a different configuration is required, please contact our Customer Service Department or the official ARCOMED distributor in your country.

3.12. Accessories and consumables

Accessories, expendable parts and single-use items may only be used if they comply with the appropriate international standard and national approvals. Syringes, filters and extension sets must be CE marked.

The Instructions for Use and the mains power supply cable are included as standard equipment with the Syramed μ SP6000.

3.13. START/STOP key (7)

The START/STOP key (7) is used to start the pump after the rate has been selected. The pump may be stopped at any time using this key. An additional function of this key is to confirm various parameters.

3.14. Prime / Bolus key (8)

The PRIME/BOLUS key (8) key is used to prime the extension set. It is also used to initiate a manual or automatic bolus (3.5).

3.15. AUDIBLE ALARM SILENCE/ OPTION key (5)

The audible alarm may be silenced for 2 minutes using the ALARM SILENCE/OPTION key (5). The audible alarm is re-activated after this period.

If there is no audible alarm, the key serves as an OPTION key which enables selection of any option.

3.16. ON/OFF \odot/\circ key (11)

The pump may be switched off using the ON/OFF key (11) if the infusion has been completed. All data displayed (rate and volume) is lost when the pump is switched off. In order to avoid switching the pump off accidentally, the ON/OFF key (11) must be pressed for at least one second before the pump switches off.

If the pump is connected to the mains, the STANDBY mode will switch in when the pump is switched off. This means that the battery will be charged and the charge condition indicated in the LCD window.

3.17. Keep-Vein-Open (KVO) - Rate

The pump may be configured to infuse at the keep vein open rate when the volume to be infused has been delivered. The KVO rate is preset at 0.3 ml/h and

may be set (by a technician) to suite individual requirements if necessary. If the set rate is smaller than than the KVO rate, the rate is not changed.

Remark: The latest standard uses the new wording Keep-Open-Rate (KOR). The meaning is identical to the KVO-rate.

3.18. Using the pump in parallel or multiple infusions

If additional infusion systems are connected to the patient's vascular system, this may lead to complications e.g. infusion of air, reverse-flow, interruptions due to alarms and inaccurate flow.

To prevent such incidents, please observe the recommendations as stipulated in DIN VDE 0753, Part 5 or contact your distributor.

3.19. Options for external connection to the pump

External equipment may only be connected to the Nurse call connector (20) if the system which results from this meets the requirements of draft norm EN601-1-1 and if their safety has been certified by an approved international body. Use cable number 94070 to connect the Nurse call system.

Please contact the Customer Service Department of ARCOMED AG for details of the RS232 interface (IR interface) and how to link it to external systems.

If an external 12/15V ac/dc power supply is used and is linked to other equipment, ensure that the safety of the system complies with IEC601-1.

4. Alarm system

4.1. Alarm causes

The electronic self-monitoring system continuously monitors the correct functioning of the pump and its displays whilst in operation. If a fault should occur, the infusion is stopped immediately and the alarm activates. The corresponding alarm symbol is illuminated continuously with a red colour and there is a continuous audible alarm. The nurse call alarm is activated at the same time.

The pump will not start:

- if no rate has been set (0 ml/h).
- if the syringe clamp is open.
- if the door is open.

During operation an audible alarm activates and the pump switches to the KVO rate if:

- the START/STOP key is operated.
- attempts are made to alter the rate during operation.

During operation an audible alarm activates and the pump stops if:

- the syringe is empty.
- battery capacity is low and the charge rate can no longer ensure controlled infusion.
- the infusion pressure exceeds the limit set.
- the syringe clamp is opened.
- there is an internal defect.

4.2. Canceling the alarm condition

After rectifying the cause of the alarm or acknowledging the rate change, the alarm condition is canceled and infusion resumed by pressing the START/STOP - key (18).

4.3. Pressure limit/occlusion alarm

If the pressure in the system reaches the set pressure limit due either to a total or partial occlusion, the alarm activates and the occlusion alarm symbol and rate display flash. The LCD window displays "occlusion! check line!" The vein site should be checked to ensure there is no complication.

If the cause of the occlusion is removed, the occlusion symbol flashes and the pump may be started again.

4.4. Near end of syringe alarm

This alarm activates 3 minutes before the syringe is empty. The rate and volume displays and the red syringe alarm symbol flash. The LCD window indicates "Empty in 3 minutes" and counts down until the syringe is empty.

4.5. Syringe empty alarm

When the total volume in the syringe has been infused, the alarm activates and the pump stops. The RATE display flashes and the red syringe alarm symbol illuminates continuously. The LCD window indicates "syringe end! reload".

4.6. Battery alarm

The pump may be operated independently of the mains power supply using the internal battery. If the mains power supply fails, the pump switches automatically to battery operation to continue the infusion without interruption.

Battery operation is indicated by illumination of the battery symbol (17). Battery capacity permits from 3 up to 12 hours operation (1.85 Ah battery) depending on the infusion rate set. After approximately 3 to 12 hours operation the battery symbol in the alarm display (14) illuminates and an audible alarm activates. Alarms are canceled automatically as soon as mains power is restored.

A low battery alert is activated approximately 30 minutes before the battery depleted alarm. The battery symbol (17) flashes and an audible alarm activates. To silence the audible alarm, press the ALARM SILENCE key (5). The battery symbol continues to flash until the pump is reconnected to the mains.

A cautionary alarm is activated if the pump is disconnected from the mains power supply whilst in operation. This alarm may be silenced using the ALARM SILENCE key (5).

4.7. Nurse call

The pump may be connected to the external nurse call system via the connector (20) on the rear of the unit using cable part number 94070. All alarms are transmitted to the nurse call station. The normal pump alarms and displays continue to function.

4.8. Alarm silence

Audible alarms may be silenced for approximately 2 minutes using the ALARM/SILENCE key (5). The audible alarm is reactivated after this period.

4.9. Alarm indicators (14)

The cause of the alarms are indicated using illuminated pictograms as shown:

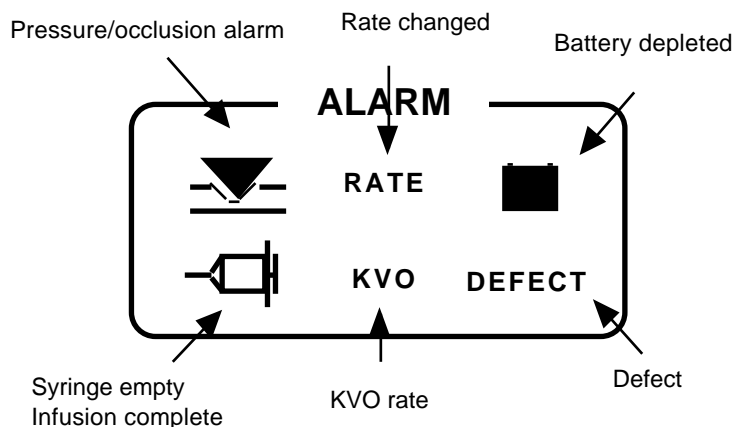

4.10. Power and running indicators (17)

These are indicated by the following:

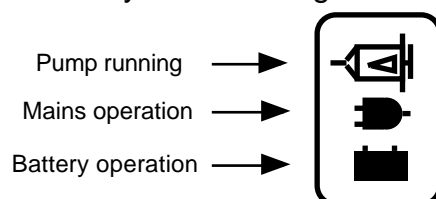

4.11. LCD window (6)

Various messages and infusion parameters are displayed in this window.

4.9. Technical description

The syramed μ SP6000 is a microprocessor-controlled infusion pump with stepper motor drive and comprehensive software management function monitoring. The pump is operating range enables infusion rates from 0.1 ml/h to 1, 500 ml/h (50/60 ml syringe) to be made. An internal rechargeable battery allows the unit to operate independently of the mains in emergencies or when used as a mobile unit. The mechanism is driven by a step motor via a toothed belt and friction spindle. All important operating parameters are clearly shown on an LED indicator. Setting the desired values is done via touch-pad keys. The unit is manufactured using the latest surface mounted control technology (SMD).

5. Warranty

Arcomed AG offers a twelve month warranty on each Syramed μ SP6000 syringe pump effective from date of delivery.

The warranty covers the installation and replacement of faulty parts if caused by faulty assembly or materials. The warranty is rendered null and void if changes or repairs are carried out by persons who have not been authorized in writing to do so by Arcomed AG or Arcomedical Infusion Ltd and if the inspection and maintenance intervals are not observed.

The warranty does not cover the elimination of problems caused by incorrect operation, inappropriate handling or normal wear and tear,
The supplier only accepts responsibility for the safety, functional reliability and performance of the equipment providing that

- assembly, extension work, resetting, modification or installations are carried out by personnel authorized by him.
- the electrical system at the operating site meets IEC requirements.
- the unit is used in accordance with these Instructions for Use.

The information provided in this manual applies to the currently prevailing situation and is given in good faith. The manufacturer reserves the right to make modifications in the interest of technical progress.

5.1. Design changes

Arcomed AG endeavour to ensure that future improvements and modifications are compatible with earlier models.

NOTE: Always state the model, serial number and where applicable the colour of the unit in question when ordering spares.

6. Scope and schedule of safety checks of the syramed® μSP6000 syringe pump

Schedule: every 24 months or after 10,000 hours operation: this unit must be checked by technical staff who have been trained and authorised in writing to do so by Arcomed AG or Arcomedical Infusion Ltd.

Check list		Check for	Result
Visual check Case, door, control panel Door latch Syringe clamp Mechanical parts, drive system Labelling Visual displays Connector, fuses		Hair-line cracks Contamination Contamination Function, clean None missing Function Damage, blown	
Functional checks Loading and removing syringes Syringe recognition Plunger lock	Use several sizes	Syringe capture	
Accuracy testing at 25 ml/h and Rate 100 ml/h Pressure transducer	Measurement of rate using water Set pressure limit to 500 mbar	as per specification Alarm response time Pressure reading	
Test nurse call system RS232 data link (only on RS 232C option)		Function Pump STOP function	
Earth leakage current Earth bonding test including mains cable	Test as in IEC 601/1	Within type CF limits 300 mOhm	

Fuse ratings must correspond to the manufacturer's specification.
(T200 mA/250V IEC127/III/SEV 1064).

Test results must be recorded in the Equipment Log.
CAUTION: After repairs and any replacement of parts, test runs must be carried out in accordance with the manufacturer's protocols.

7. Performance data

7.1 The significance of trumpet graphs in clinical practice

Trumpet graphs indicate the maximum and minimum percentage deviation from the set flow rate for observation windows of duration 2 to 31 minutes. The maximum deviation from the set rate can therefore be determined for clinically relevant periods of time. For instance, many drugs used for infusion have a pharmacological and biological half-life of less than 5 minutes.

One agent commonly used to support the cardiac output in a critically ill patient has a half-life of 2.5 minutes. When infusing this agent, it is important that the fluctuations in flow from the syringe pump measured over a time period of 2.5 minutes, do not cause the therapeutic limits of the drug to be exceeded. It has been observed that cardiac stability can be disturbed by excessive fluctuations in pump output over short time periods.

Fluctuations in pump output depend to a great extent on the rate set and decrease as the rate is increased.

Remark: Performance data on other syringes can be requested at Arcomed. The accuracy depends mainly on the tolerances of the syringes.

Table 1: Mean accuracy measured over 60 minutes (typical values)

<u>rate (ml/h)</u>	<u>measured rate (ml/h)</u>	<u>% error</u>
1.0	1.01	0.75
2.0	1.99	-0.12
5.0	4.91	-1.83
25.0	25.25	+1.00

Table 2: Short term accuracy (typical values)

<u>rate (ml/h)</u>	<u>2 min window</u>		<u>5 min window</u>	
	Max	Min	Max	Min
1.0	+4.84%	-3.70%	+3.89%	-2.18%
2.0	+3.35%	-2.65%	+1.81%	-0.89%
5.0	+1.97%	-1.30%	+0.90%	-0.38%
25.0	+0.95%	-0.66%	+0.67%	-0.50%

Weight [mg]:

50390.1

Flow:

25.25

ø Flow:

25.250

ø Error[%]:

1.000

Time:

120.30

File Name:

µSP6000-25ml/h(Plastipak 50 ml)

Rec. date:

8.9.1998

Rec. time:

0:05:39 Uhr

Rate (ml/h):

25

Evaporation:

0.05

Scans:

240

Interval (s):

30

Flow [ml/h]:

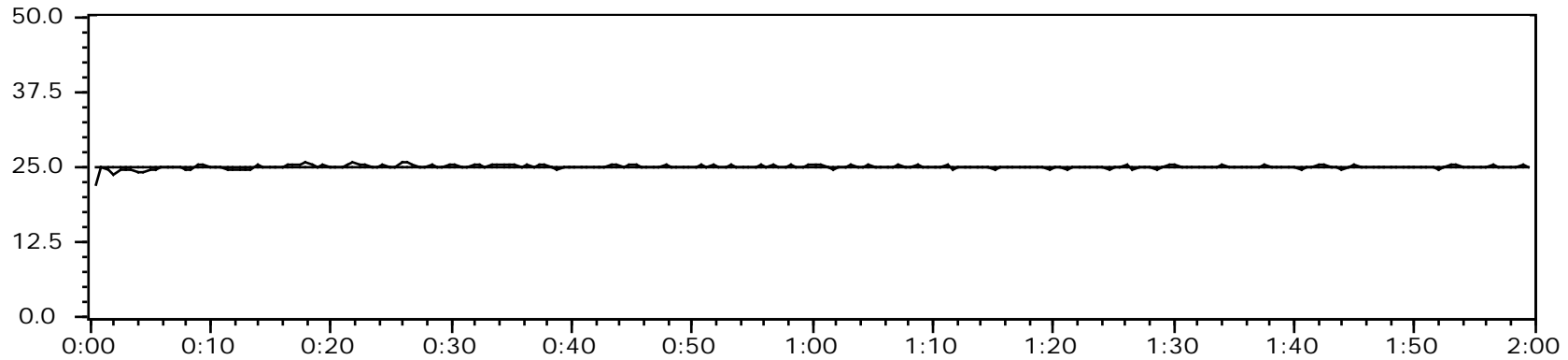

Trumpet Curve:

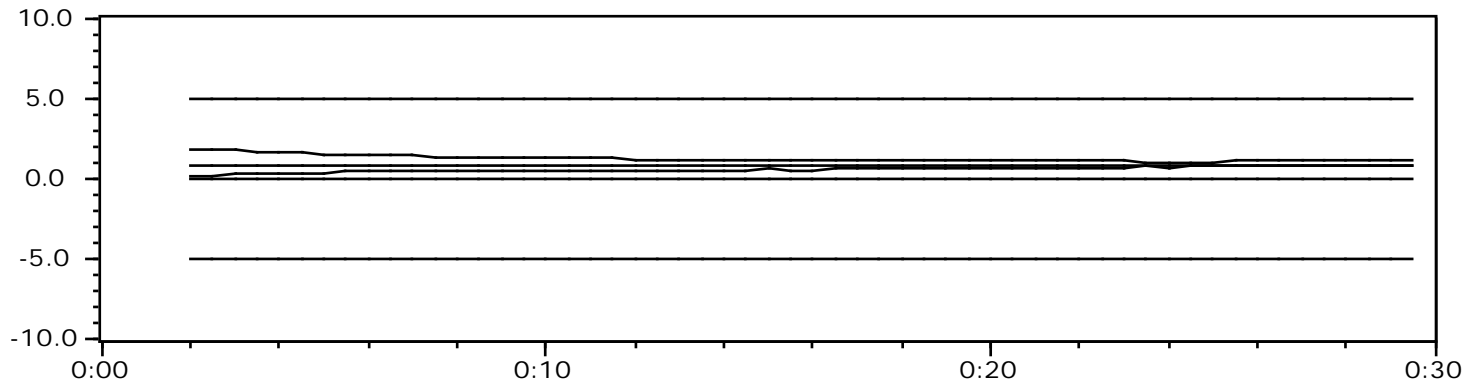

2 Min (max):

0.95

2 Min (min):

-0.66

5 Min (max):

0.67

5 Min (min):

-0.50

Weight [mg]:

3894.4

Flow:

2.04

ø Flow:

1.997

ø Error[%]:

-0.120

Time:

120.30

File Name:

µSP6000-2 ml/h (Plastipak 50ml)

Rec. date:

10.7.1999

Rec. time:

9:59:49 Uhr

Rate (ml/h):

2

Evaporation:

0.05

Scans:

240

Interval (s):

30

Flow [ml/h]:

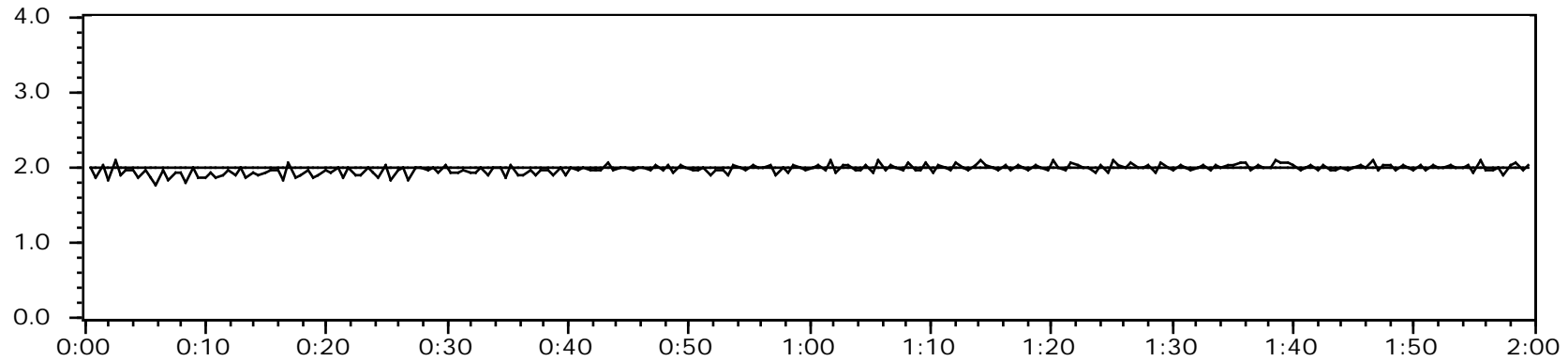

Trumpet Curve:

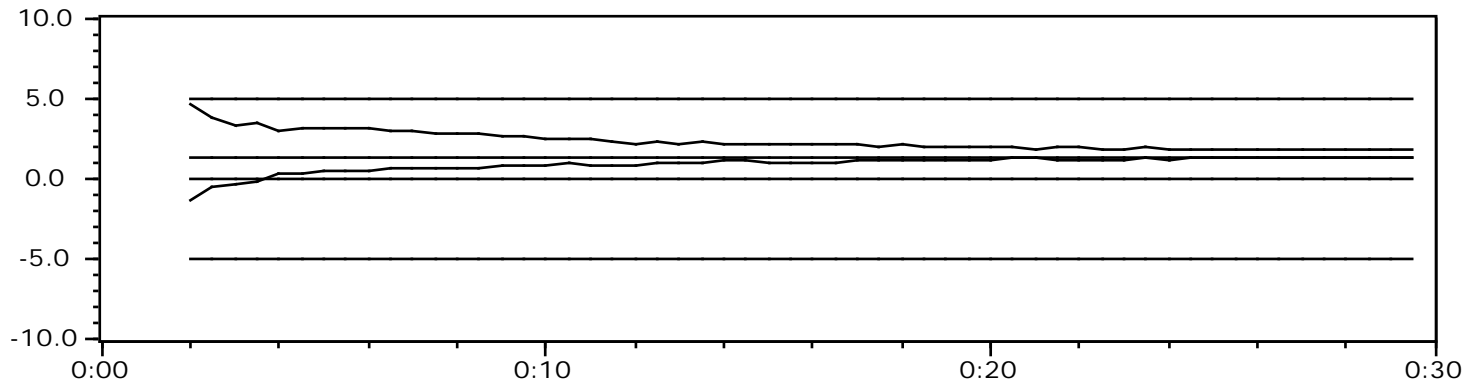

2 Min (max):

3.35

2 Min (min):

-2.65

5 Min (max):

1.81

5 Min (min):

-0.89