

Instructions for use

Volumed μ VP5005

CE₀₁₂₃

Swiss Made

ARCOMED AG

**8105 Regensdorf - Zürich
Switzerland**

(an ISO 9001 company)

Edition 18/01 -VA-GA-5005-E

Contents

	Page
Index numbers	0
1. Introduction	1
2. Specifications	3
3. Operation	4
3.11 Parallel / Multiple Infusions	6
4. Alarm Supervision System	7
5. Special Key Inputs	10
6. Warranty	11
Design Changes	
7. Inspection and Maintenance Intervals	12
8. Significance of Trumpet Curves	13

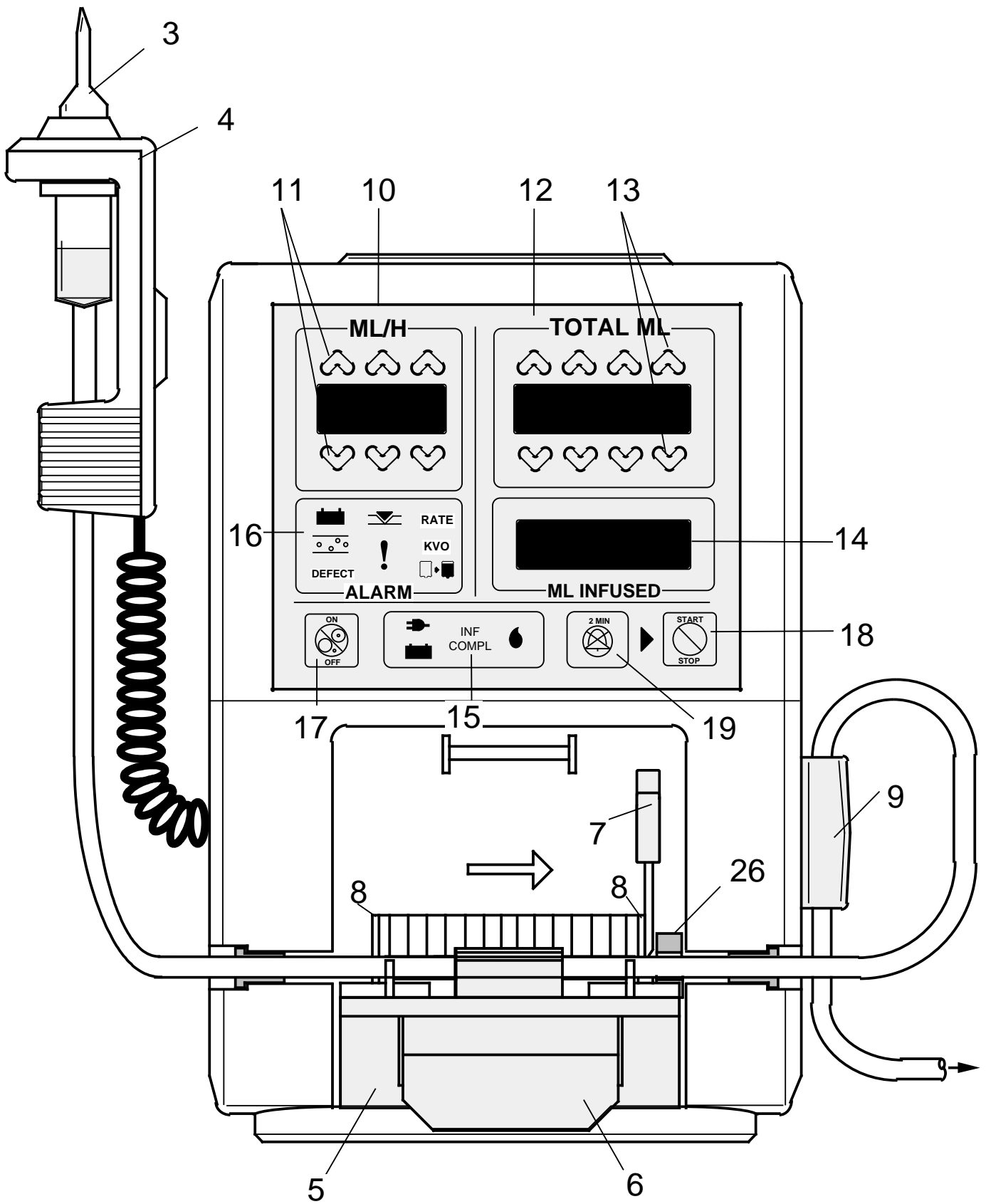

Front view μVP5005 -UK

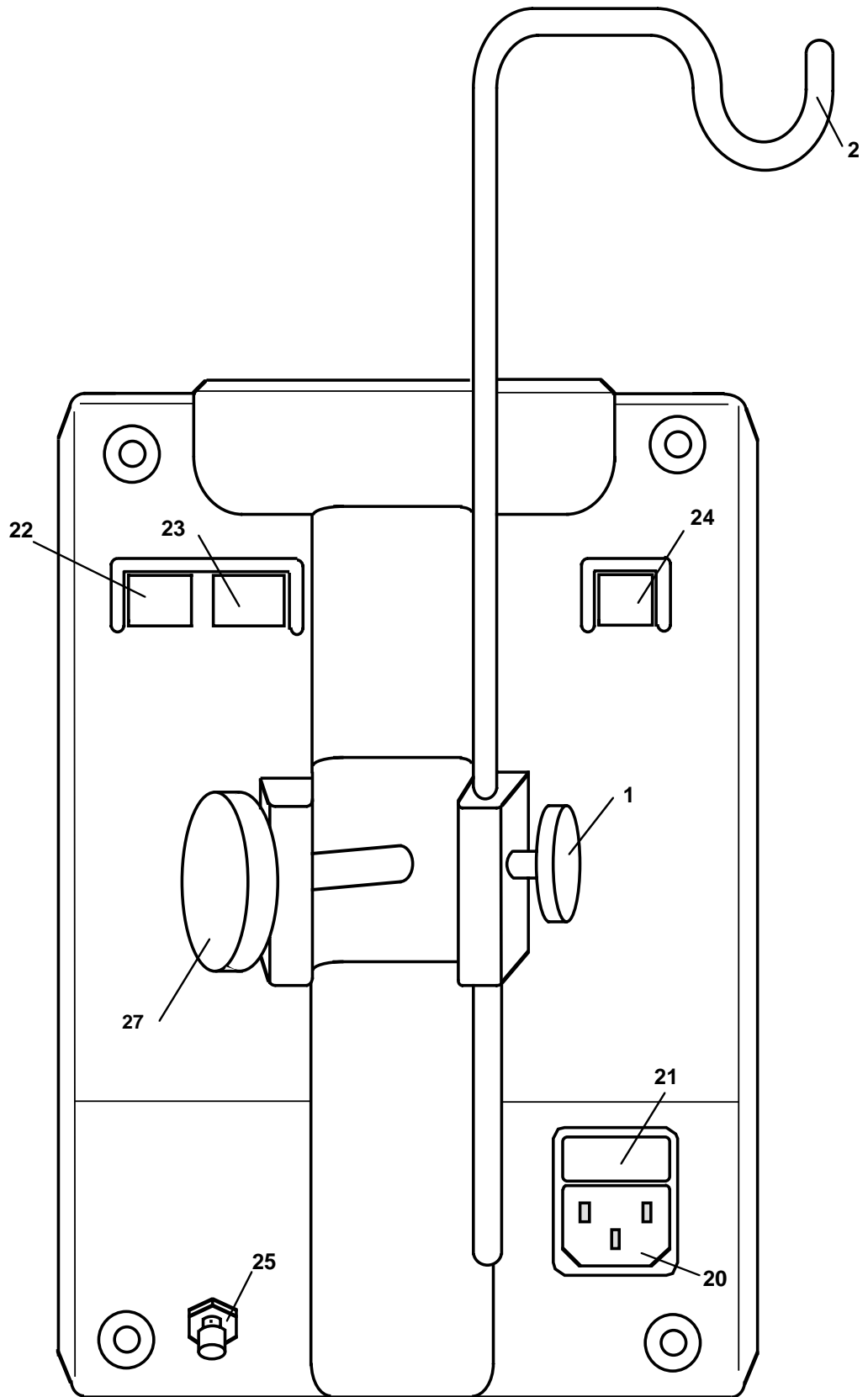

Rear view μ VP5005

Index numbers

1	Knurled screw
2	Bottle / Plastic container support
3	Drip chamber
4	Empty container detector (ECD)
5	Pump door
6	Door latch
7	Stop-flow lever
8	Tube guides
9	Air detector
10	Rate display
11	Rate keys
12	Volume display
13	Volume keys
14	Infused display
15	Information window
16	Alarm window
17	ON/OFF key
18	START/STOP-key
19	Alarm tone-mute key
20	Mains supply socket
21	Fuses
22	Nurse call
23	Option RS232
24	Input external drop detector
25	Earth potential plug
26	Pressure detector
27	Infusion pole clamp knob

1. Introduction

1.0 General

The Volumed® μ VP5005 Volumetric Infusion Pump has been developed using the latest state-of-the-art technology. The pump has been manufactured and tested to meet the VDE specification „Safety of Electromedical Apparatus - General Requirements“ DIN IEC 601 Part 1 or VDE 0750 Part 1/05.82 and the draft German Standard E VDE 750 Part 232 and Appendix A1. The pump has also been built and tested to Swiss SEV, German TÜV-PS , UK BSI 5724 and BS800 and French M.O.H specifications. It has been designed to comply with IEC 60601-2-24.

The Volumed® μ VP5005 meets the Medical Device Directive (MDD) requirements of the EC Guideline 93/42 EEC and is marked CE 0123 (TUV PS Munich, Germany).

The manufacturer according to MDD is Arcomed AG, Althardstrasse 146, CH 8105 Regensdorf, Zurich, Switzerland. The person responsible for the EC is Mr. Rob Bradshaw, Arcomedical Infusion Ltd., West Horndon, Essex CM13 3XL, UK.

The Volumed® μ VP5005 may be operated only on mains power installed to DIN 57107 VDE 0107 or the appropriate national standards. If the integrity of the mains power supply protective earth system is in doubt, the pump should be operated on battery power. Mobile telephones should not be used anywhere near this equipment.

Every effort has been made to ensure this manual's completeness. If there are any queries with regard to the product's use or any ambiguity, you are advised to contact our Customer Service Department in or the official distributor in your country.

Switzerland: ARCOMED AG, Althardstr. 146, CH-8105 Regensdorf/Zurich, Switzerland.
Tel: +41 1 840 47 40, Fax: +41 1 840 06 49

United Kingdom: Arcomedical Infusion Ltd., 5J West Horndon Industrial Estate, West Horndon, Essex CM13 3XL, England.
Tel: +44 1 277 810432, Fax: +44 1 277 811967

1.1 Device set-up and installation requirements

Unpack and check the Volumed® μ VP5005 and accessories. Should there be any physical damage, the equipment must not be used.

The standard accessories are the empty container detector, integral infusion pole, this user instructions and a mains cord.

The unit when used with on mains, must only be installed with the supplied cord-set from Arcomed or approved to BS 1363A by a recognized Test House.

Warnings:

- do not use this equipment on mains power if the integrity of the protective earth system is suspect.
- to prevent a possible explosion hazard do not use this equipment in presence of inflammable anesthetic gases.
- do not use this equipment in close proximity to equipment such as surgical diathermy with generates high levels of RFI.
- do not permit the use of portable telephones in wards where this equipments is in use.
- do not permit this equipment to used if standing in a pool of liquid.

1.2 Routine and maintenance procedure

It is advisable to keep the pump clean and to carry out routine maintenance periodically. A mandatory safety and performance test must be performed every 24 months or after 10'000 hours of use. (see chapter 7). Maintenance carried out annually ensures optimal performance and prolongs the life of the product.

Should the pump be dropped or damaged in any way, it should be examined by a suitably qualified service technician or returned to the manufacturer for inspection and test.

1.2.1 Cleaning, disinfection and storage

CAUTION: The pump must be switched off and disconnected from the mains power supply before cleaning and disinfecting.

The pump must be kept clean and dry. Remove any spillage immediately. The pump must not be placed in an autoclave.

The unit is disinfected by wiping over with a cloth which has been damped slightly with an alcohol-based disinfectant. Take care when cleaning that no liquid enters the inside of the pump case. Wait at least 30 seconds after disinfecting before switching the pump on.

1.2.2 Routine maintenance

The following schedule is suggested:

- 1) Clean the pump after each infusion.
- 2) Every 4-8 months (according to usage) check if all alarm systems are operative, inspect mains cord and mains connections and perform routine self test, calibration* and battery check.
- 3) Please refer to the chapter 8 for further details.

*Use an established test procedure or refer to the maintenance manual for advice. Circuits, calibration instructions and component list etc. will be made available to appropriately qualified technical personnel.

1.3 Description of Symbols



external empty
container detector



nurse call

COM

interface RS232



cardiac floating (CF) - type unit - equipment with a floating applied part, providing an adequate degree of protection against electric shock.



Attention: consult accompanying documents.

IPX 1

drip-proof - equipment provided with sufficient protection to prevent fluid ingress.



equipotential point - terminal connected to earthed conductive parts within the device. For connection to a potential equalization conductor, used in medical environments where potential equalization is required.

2. Specifications μ VP5005

Classification	IIb
CE certificate number	G5 00 11 13006 008
Flow rate range (Option) (Micro-pump)	1 - 600 ml/h (999 ml/h) (0.1 - 99.9 ml/h)
Resolution (Micro-pump)	1 ml/h (0.1 ml/h)
Deviation in flow-rate with 3101P series administration set	typ. +/- 5%
Max. overinfusion (Mech./electr. Defect)	0.5 ml
„KVO“ vein open rate (Micro-pump)	3 ml/h (0.3 ml/h) or set rate if less
Infusion pressure min.	60 kPa / 450 mmHg / 0.6 bar
Infusion pressure max.	150-250 kPa / 1125-1875 mmHg / 1.5-2.5 bar (according to IV set)
Pressure alarm-limit (Option)	adjustable 0-999 mbar / mmHg
Air detection	ultrasonic
Sensitivity	typ. 100 μ l, adjustable from 50 to 250 μ l
Battery operation, charged (1.2Ah)	> 3h
Unit charging time OFF/ON	15 h / 20 h
Supply connection	230/240 VAC +10%-15%, 50-60 Hz
Input current	80 mA
Mains fuses (F1,F2)	250 mA/IEC127/III/ SEV 1064
Classification of electrical safety	Class I / Type CF
Leakage current	< 40 μ A
Protection against ingress of liquids	IPX1, drip-proof
Equipotential bolt	DIN 42801
Nurse call	
Potential-free contact switch	24 V/ 0,2 A
Dimensions with ext. Empty Bag Detector	(WxHxD) 160x240x210 mm
Dimensions with int. Empty Bag Detector	(WxHxD) 190x240x210 mm
Casing	High impact ABS plastic
Weight	3,9 kgs
Temperature range Operating/Storage	15°C - 35°C / 0°C- 40°C
Permits. rel. humidity	max. 85%, no vapor deposit
Max. storage time	3 months without charging
Safety testing	IEC 60601-1 IEC 60601-2-24 IEC 60601-1-2 EMC

Time to alarm after occlusion (3101P)

Pressure Rate	with opt. pressure sensor		
	2.5 bar	500 mbar	100 mbar
1 ml/h	>120 min	45 min	8 min
20 ml/h	10 min	100 sec	20 sec
100 ml/h	100 sec	25 sec	5 sec
999 ml/h	12 sec	2.5 sec	0.5 sec
Bolus	2.3 ml	0.45 ml	0.09 ml

3. Operation

An illustration of the front panel of the Volumed μ VP5005 together with a full explanation of reference numbers is to be found at the beginning of this Maintenance Manual.

Caution:

Use only IV administration sets or Arcomed approved equivalent.

(20 drops/ml, PVC-standard - IV - set: type 3/4mm, Shore-hardness: Shore A, 78)

The performance data depend on the IV-line / pump system. The use of a IV-line has to be in accordance with the technical adjustment of the pump.

If other IV administration sets are used, the operating safety of the pump can no longer be guaranteed. Patient safety may, as a result, be compromised.

In accordance with the norm E VDE 750 Part 232 and Appendix A1, the IV-set should be replaced every 24 hours. The IV-sets are for single use only (BS 5724).

3.1. Preparation / Insertion of the IV-set

- a) If the unit is mounted on a floor stand, care must be taken to ensure that it is fixed at a height not exceeding 1.2 m above floor level, in order to ensure stability. The unit can also be placed on a flat surface.
- b) With the aid of the knurled screw (1) on the back of the unit, the bottle/container holder (2) can be adjusted so that the drip chamber (3) is held firm by slotting it into the empty container detector (4). Make sure that there are no large ribs or joints in the passage of the empty container detector and that fallen drops are detected by the drop-detector's light-barrier.
- c) Carefully purge the infusion set, without allowing any air bubbles to enter, until the drip chamber (3) is 1/4 to 1/3 full. If air has entered, repeat purge-procedure.
- d) Close the tubing roller clamp.
- e) Open the pump chamber door (5) by raising the door latch (6).
- f) Press back the red handled „stop-flow“ lever (7) until it is inside the recess.
- g) Starting with the left side, insert the IV set into the tube guides (8). Ensure that the flow direction of the pump from the left to the right is respected. Insert the tubing carefully in the air detector (9) from top to bottom in the direction of the arrow. Ensure there is a loop between the pump door outlet and the air detector.
- h) Close pump door (5).
- i) Open tubing roller clamp. Check that there is no „free-flow“.
Plug the power supply cable into the back of the pump and connect it to an AC power supply outlet unless battery operation is required. The AC operation power indicator (15) will light up and battery charging will commence. If not, check power cable and both fuses (24).

Note: The power supply must include a reliable earth connection for safety. An earth terminal is provided on the back of the unit (25) for connection to an independent protective earth system if necessary. If the integrity of the protective earth system is in doubt, always operate the pump from its internal battery supply.

- k) Press ON/OFF key (\odot/\circ) (17). The audible alarm beeps once together with the indication < ! > in the alarm window (16). The software version number (μ VP5005, rx.xx) and the configuration of the pump (μ VP5005, c.xxx) light up briefly.

3.2. Rate (ml/h)

Set the desired rate with the Up/Down keys (11) in the rate display(10). Keys with arrow up increase the rate, those with arrow down decrease the rate in single steps.

3.3. Total volume (TOTAL ML)

After setting the rate, use the Up/Down keys (13) in the total ml display (12) to set the total volume to be infused. When the Volumed® µVP-5005 reaches the preset total volume the pump goes into infusion complete (indication window), gives an audible alarm and the rate will be switched to the KVO rate.

If no total volume is desired, the pump can be started directly after setting the rate.

3.4. Alternative operation

If you want to use one of the following variants, please contact our Customer Service Department or contact the approved ARCOMED distributor for your country (see also point 1.1).

a) Reset the MI Infused

Reset of the MI Infused after every Start/Stop.

b) SBS (Step by step) or titration

If the volume is increased after reaching the preset total volume, only the difference between the new and old values is infused when the pump is restarted. Volume infused can be either accumulated or not.

c) Storage of the last set ml/h rate and total ml.

d) Display of time infused and or drops infused.

e) Adjustment of the audible alarm volume level.

3.5. START/STOP

Once the rate is set, the pump can be started with the START/STOP key (18). At every fallen drop the drop lamp in the indication window (15) lights up.

3.6. Infused display (ML INFUSED)

In the MI Infused display (14) the actual volume is indicated. This indication is not influenced by starting/stopping the pump, however it is reset after the total volume is reached and the pump is restarted again. Also turning off/on the pump resets the volume infused.

3.7. Alarm tone-mute key

The audible alarm can be suppressed for 2 minutes by using the alarm tone-mute key (19). After two minutes the audible alarm will automatically restart if the pump is still in alarm condition.

3.8. ON/OFF (/) -Key

To turn On/Off the pump the ON/Off key (17) is used. This resets the rate ml/h, total ml and infused ml values to zero. The ON/OFF key has to be held down for more than 1 second to turn off the pump. This prevents the pump from being turned off accidentally.

This switch is not a mains isolating switch, and the battery charging circuit is always connected to the mains (stand-by).

3.9. IV container exchange

When changing the plastic container or bottle, infusion can be interrupted at any time by means of the 'Start/Stop' key (18) without affecting the set or displayed values. In this state, handling operations such as changing the container or IV set and rate changes can be implemented without activating the alarm. In the stop mode, 'KVO' operation is automatically activated.

If the pump remains in the stop mode for more than 4 minutes, the audible reminder alarm will sound.

3.10. Keep-Vein-Open (KVO)

In certain conditions the Volumed® µVP5005 automatically switches to the KVO-rate (Keep-Vein-Open rate). The KVO-rate is set to 3 ml/h (0.3ml/h Micro Pump mode). However, if the rate set by the user is lower than 3 ml/h, the KVO-rate is equal to this rate.

3.11. Use in parallel or multiple infusions

if several pumps are linked together for multiple or parallel infusions, infusion of air, reverse infusion or deviation of the flow rate might occur. If in doubt, please refer to the matrix in the VDE 0750 part 5 or equivalent specifications for the correct set-up of your system.

3.12. Use of Disposable IV administration sets

Alternatives to our recommended 3101P sets can only be used, if their use is not in discrepancy with the security of the system and if the equipment has been certified by a qualified laboratory or institute.

3.13. External interconnections

When interfacing via the connector (22) and (24), only equipment can be used which meets the specifications of the IEC 601-1-1:1992 or when it has been proved by a certified body that there is no influence on the safety of the system.

- Use only the external empty container detector Nr. 98502 (24)
- Use the cable 94070 for the nurse call (23)
- For the RS 232C (optional 20mA passive interface), please contact our Service department (see 3.4).

3.14. Environment

Used IV set are dangerous and must be discharged according to the local regulations. Used batteries must be recycled or returned to the supplier. A list of the used materials can be obtained from our service department.

4. Alarm supervision system

4.1. Alarm causes

During the operation of the unit, the built-in supervision system continually checks that the pump is operating correctly. In the event of a malfunction, the infusion is immediately suspended and the alarm is activated. This is signaled by the lighting up of the 'ALARM' display (15) with the corresponding alarm symbols continuously illuminated in red and by an intermittent audible alarm. At the same time, the nurse call system will be activated. If there is no 'Occlusion' or 'Air alarm', the KVO rate is activated.

The Volumed® μ VP5005 cannot be started:

- if the infusion tubing is not inserted or is incorrectly inserted in the air detector (4).
- if the rate is not set (0 ml/h).
- if there is an occlusion or the door is open (alarm through optional pressure sensor).

During operation, the Volumed 5005 switches on the audible alarm and 'KVO' operation if:

- handling operations are performed on the rate or total input keys (11 and 13)
- the 'Start/Stop' (18) key is actuated
- the infused quantity has reached the preset total volume value. During operation the Volumed® μ VP 5005 emits an audible alarm and goes into the 'Stop' mode if:
 - a deficit/excess total number of mls are detected in relation to the ml/h rate
 - the liquid level in the drip chamber is too high
 - the tubing roller clamp has not been opened
 - the infusion bottle or plastic container is empty
 - the charge state of the battery can no longer guarantee continuous infusion
 - the pressure in the tubing exceeds the maximum permissible value
 - the infusion tubing contains air bubbles
 - the infusion PVC tubing is not fitted correctly in the air detector
 - the door is open.

4.2. Cancelling the alarm condition

After rectifying the cause of the alarm or acknowledging the rate change, the alarm condition is cancelled and infusion resumed by pressing the START/STOP key (18).

4.3. Air bubble detection

The μ VP5005 goes in the following cases in air in line alarm:

- a) If there is a total of 500 μ l of air within 15 minutes. Individual small air bubbles (>50 μ l) will be integrated during a time window of 15 minutes.
- b) If there is an air bubble greater than 50 - 250 μ l adjustable.

The air bubble alarm will light up and the audible alarm starts. If the air in line has been solved, the air bubble alarm blinks and the pump can be started.

4.4. Battery Alarm

The built-in battery enables the Volumed® μ VP5005 to be used independently of a mains supply. In the event of a mains failure, the pump automatically passes into battery operation, without interrupting the infusion. If the battery is completely discharged, the pump goes into battery alert. The battery alarm symbol in the alarm window lights up and an intermittent audible alarm starts. However, the pump runs normally for at least 3 minutes before stopping. If the mains supply is connected in the meantime, the alarm is automatically cleared.

The Volumed® μ VP5005 can also be programmed as to have a prealarm about 30 minutes before being stopped, which is indicated when the green battery symbol is flashing. In this mode the battery also starts flashing when the mains supply is disconnected. In both cases the audible alarm can be muted by pressing the alarm tone-mute key (19).

Charging the battery takes about 20 hours while the pump is in operation, 15 hours if the pump is turned off.

4.5. Nurse call alarm

The unit can be connected to an external call system by means of the connection socket (22) on the rear of the unit. For each alarm, the nurse call is thus transferred to the call station. This does not affect either the optical alarm display of the pump or the audible alarm system.

4.6. Alarm tone-mute switch

By pressing the alarm tone-mute key (19) the audible alarm can be muted for a period of 2 minutes. After the muting time has elapsed, the alarm again sounds until the cause has been eliminated.

4.7. Alarm indications and their meaning

In order to be able to determine quickly the cause of the alarm, the alarm situations are indicated by illuminated pictograms in the alarm window (16):

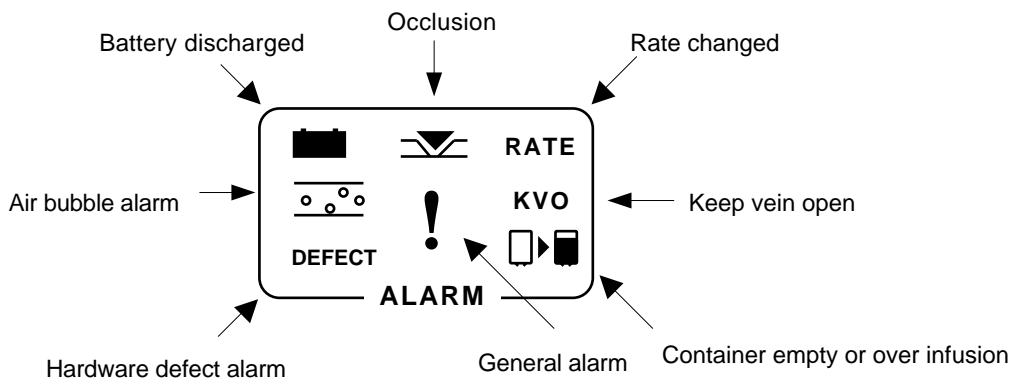

4.8. General indications and their meaning

In the indication window (15) further information is indicated as:

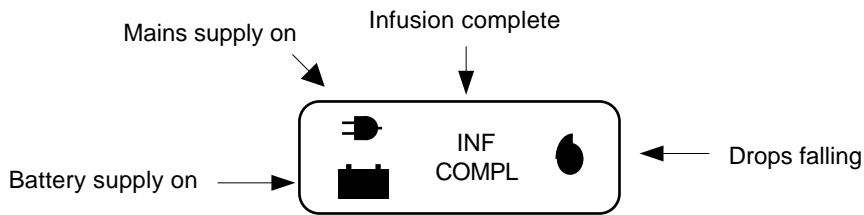

4.9. Technical description

The microprocessor controlled peristaltic pump Volumed® μ VP5005 is supplied with a step motor drive and comprehensive software monitoring. The operating range of the pump allows rates from 0.1-999 ml/h to be selected. An integrated, rechargeable battery permits mains-independent operation for emergencies or for ambulatory use.

A mechanical stop flow is installed behind the door to prevent the infusion solution from flowing freely in the event of the pump door being opened inadvertently. The peristaltic system is driven by a step motor via a positive-engagement toothed belt, with the individual blade movements being controlled by an eccentric camshaft. These blades are fully protected by a rubber cover.

All important operating parameters are clearly reproduced on an LED display. The desired values are entered via a keypad. The unit incorporates state-of-the-art SMD circuit technology.

5. Special key inputs for auxiliary displays

Display test and recall of the last values:

Hold the Start/Stop key (18) while turning on the pump. Check whether all displays light up in the correct sequence (..6789).

In this Display test mode, last ml/h, total ml, ml infused and the pressure limit (option pressure-transducer) of the last infusion will be recalled and displayed.

Display of the software version number:

Hold the „Total 1000ml down“ key while turning on the pump. The software version number (µVP5005, r1.xx) is displayed. After about 10 seconds the pump switches to normal operation.

Display of the configuration:

Hold the „Total 100ml down“ key while turning on the pump. The configuration (µVP5005, c.xxx) is displayed. After about 10 seconds the pump switches to normal operation.

Display of the pump serial number:

Hold the „Total 10ml down“ key while turning on the pump. The pump serial number (P.nr. xx.xx xxxx) is displayed. After about 10 seconds the pump switches to normal operation.

Display of the hospital inventory number:



Hold the „Total 1ml down“ key while turning on the pump. The hospital inventory number (no xxxx) is displayed. After about 10 seconds the pump switches to normal operation.

Micro-pumping-mode:

Hold the „Rate1ml down“ key while turning on the pump. The pump switches to the micro pump mode. Rates can be set from 0.1 to 99.9 ml/h and the total volume to be infused from 0.1 to 999.9 ml. Carefully watch the decimal point in the 3 displays. Otherwise the pump operates exactly the same as the standard version 1 to 999 ml/h.

Attention: When turned off in the micro pump mode, the µVP5005 automatically reverts to its standard version when switched on again, unless permanently configured through the software code access.

Pressure display mode (option):

Press audible alarm 2 min suppression key (19) once while the pump is running. Line pressure in mbar or mmHg will be displayed for 20 sec in the ml infused display (14). By pressing the same key twice in quick succession, not only will the pressure in mbar or mmHg be displayed in the ml infused display (14), but the pressure level will also be displayed in the total ml display (12). During this 20 sec time period, the pressure level can be adjusted below or above the preset 800 mbar or mmHg to a maximum of 999 or a minimum to suit the displayed in line pressure. Remember the lower the pressure level, the lower the bolus occlusion on release and the quicker the time to alarm. As soon as the line pressure exceeds the prescribed pressure level, the pump will go into occlusion alarm  in the alarm window (16). An audible alarm will also be triggered. Once the occlusion has been released, the visual occlusion symbol  will flash, and both the general alarm ! and audible alarm will continue until the START/STOP key (18) has been pressed.

Caution: Do not open the door if the system is under pressure!

6. Warranty

ARCOMED AG offers a 12-month warranty on every Volumed 5005 unit, effective from the date of delivery.

The warranty covers the repair and replacement of faulty parts due to manufacturing or material defects. This warranty is rendered null and void if the unit is tampered with by unauthorized persons and if the inspection/maintenance intervals are not observed.

This warranty does not cover the elimination of problems caused by incorrect operation, inappropriate handling or normal wear and tear.

The supplier only accepts responsibility for the safety, functional reliability and performance of the unit providing that:

- assembly, extension work, resetting, modification or repair work has been carried out by personnel specifically authorized by him,
- the electrical system at the operating site meets the IEC requirements, and the unit is operated in accordance with these instructions for use.

CAUTION:

The Volumed® μ VP5005 may only be used with accessories, expendable parts and consumable items which have been authorized by ARCOMED AG as being approved as being safe.

The information provided in this manual applies to the currently prevailing situation and is given in good faith. We reserve the right to make modifications which may be in the interest of technical progress.

6.1. Design changes

ARCOMED endeavor to ensure that future improvements and modifications are compatible with the earlier models.

NOTE: When ordering spares, always state the model, serial number and where applicable the color of the unit in question.

7. Inspection and maintenance intervals Volumetric Infusionpump

Volumed® μ VP5005 (according MDD)

Interval: After 24 months or 10'000 h of use.

The following checks must be done by an engineer with sufficient technical background to comply with the safety regulations.

What to do	How / Equipment	Remarks/Result	
Visual Check			
Housing		Physical damage	
External empty container detector (ECD) (Easy Clip)		Physical damage	
or Internal empty container detector (ECD) (especially spring)		Physical damage	
Door, door latch		Clean, function	
Stop-flow lever		Clean, function	
Cover for peristaltic blades		Physical damage	
Inscriptions, display		Readable, damage	
Display - LED		Function, display test	
Mains plug, fuses		Damaged, values	
Air in line		Physical damage	
Functional checks			
o <u>Spring plate</u>	manual	check free motion	
o <u>Pressure checks:</u>	IV-set filled with water, manometer & syringe		
o minimal mechanical pressure:	preload system with syringe to 0.7 bar 4 min. at rate 5 ml/h (press. limit 999 mbar)	watch manometer pressure always above 0.6 bar	o alternative test PTD-5000 p min =
o maximal mechanical pressure:	rate 400 ml/h (press. limit 999 mbar)	pressure always below 2.5 bar*	p max =
o <u>Pressure Sensor (option):</u>	rate 100 ml/h pressure limit 500 mbar make occlusion on set	alarm reaction within 20 sec \pm 10 sec	
o <u>Rate check:</u>	Rate 100 ml/h Total of 100 ml	<u>\pm 5 % accuracy</u> Refer to trumpet curve (tech manual)	o alternative test VT-5000 % dev =
<u>while running on 100 ml/h</u>			
o simulate missing drops	Take out drop chamber of ECD detector	Visual and acoustic alarm	
o simulate Air in Line	Take out IV - set of Air Detector	Visual and acoustic alarm	
o check nurse call	e. g. open door while pump is running	alarms and switching signal at connector	
o (External pump stop	only Option RS 232C)		
<u>Electrical safety according to IEC 601</u>	Safety Tester IEC 601	IEC 601.1, section 19	
o Leakage current	75 μ A		
o Resistance protective conductor	100 mOhm		

The rates of the fuses must comply with the rates recommended by arcomed (producer):
Conventional transformer 230V :100 mA/250V, toroid transformer 230V: 250 mA/250V,
toroid transformer 115V: 500mA T/250V (IEC127/III/SEV 1064).

Caution: After any work on the pump (e. g. adjustment of programming, change of parts, any opening of the pump) this inspection must be made and all checks must be documented with the serial number of the pump. * depending on set.

Serial Number:

Remarks:

Date /Signature:

8. Significance of trumpet curves for practical use

Trumpet curves indicate for 5 different observation windows the maximum and minimum mean values of the flow rate in ratio to the preset flow rate.

Known therefore is the discrepancy per time-window. For optimal use of the infusion pump Volumed® µVP5005, the trumpet curve is an important factor in deciding whether the pump can be used with the prescribed drug.

Volatile drugs with short therapeutic half life demand high accuracy.

For a drug where the plasma-half life is e.g. 1 min. discrepancy of the flow rate of 15% per minute would mean the same discrepancy for the plasma level. Therefore, a predictable constant impact of the drug would not be guaranteed.

Example:

Intravenous infused Insulin has a therapeutic half life of 15 minutes. A flow deviation of ± 15% within 40 minutes would have at least the same (rather twice as much) influence on deviation of the plasma level and therefore on its impact.

This is unacceptable to physicians and nursing personnel.

It is important to know that the deviation in a short observation window depends strongly on the preset rate. The Volumed® µVP5005 has at a rate of 25 ml/h a deviation smaller than ±2% in a observation window of 2 minutes. With 5 ml/h the deviation in the same observation window is ± 4%, within 5 minutes it is 2%. Mean deviations are within ±5% (see also following table).

Table 1: Flow Accuracy of the Volumed® µVP5005 (typical values)

Rate (ml/h)	Observation window					
	2 min		5 min		11 min	
	Max	Min	Max	Min	Max	Min
5.0	+2.24%	-3.77%	+0.64%	-1.03%	+0.60%	-0.60%
25.0	+1.47%	-1.05%	+0.67%	-0.57%	+0.30%	-0.37%
50.0	+0.67%	-0.66%	+0.49%	-0.54%	+0.35%	-0.39%

Rate (ml/h)	Measured Flow Rate (ml/h)	Flow Rate Error (%)	Test Duration (h.min)	Sample Duration (h.min)
5.0	5.115	2.30	2.00	1.00
25.0	25.341	1.37	2.00	1.00
50.0	48.558	-2.28	2.00	1.00

Weight [mg]:

49056.4

Flow:

25.10

ø Flow:

24.533

ø Error[%]:

-1.867

Time:

120.30

File Name:

Volumed 5005 25ml/h

Rec. date:

24.4.2001

Rec. time:

13:28:05 Uhr

Rate (ml/h):

25.0

Evaporation:

0.00

Scans:

240

Interval (s):

30

Flow [ml/h]:

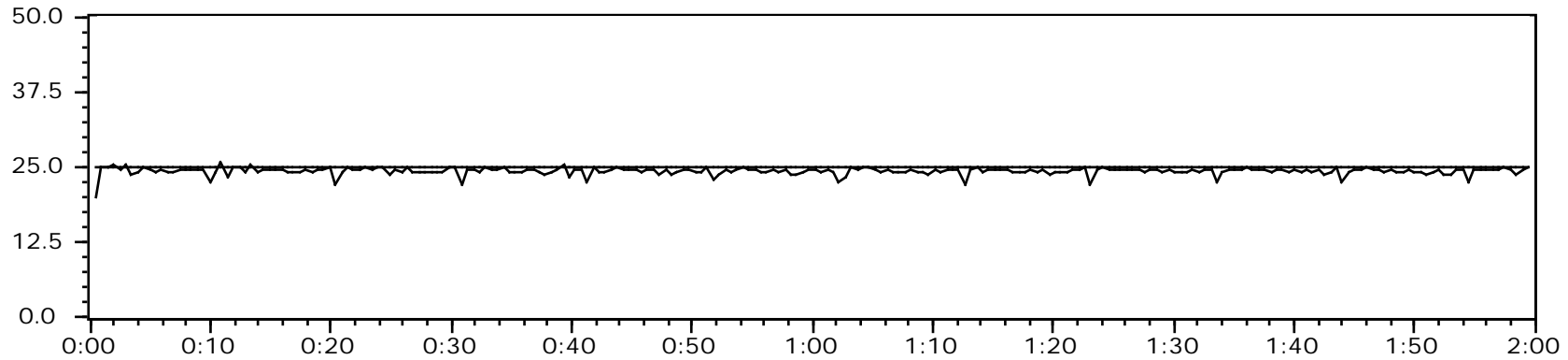

Trumpet Curve:

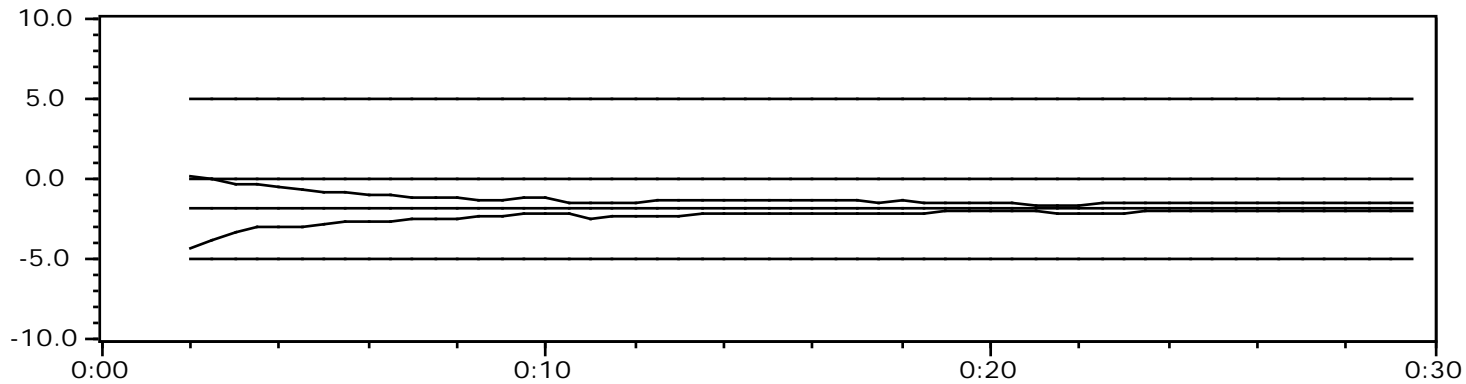

2 Min (max):

2.04

2 Min (min):

-2.46

5 Min (max):

1.04

5 Min (min):

-1.01

Typical trumpet curve Volumed® μ VP5005 at 5 ml/h

Notes:

Special Keys

Volumed® µVP5000/5005

1) Start up - keys:

Hold indicated key while switching on pump

Micro Pump

Starts Micro Pump 0.1 ml/h ... 99,9 ml/h

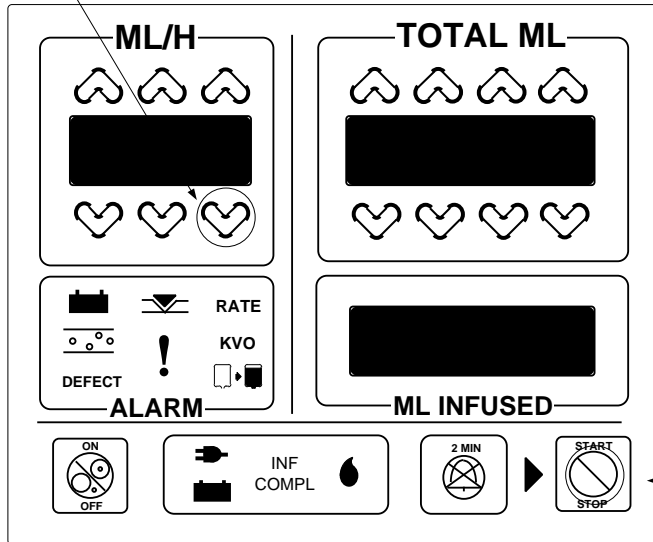

Display Test Memory Key
Recalls previous setting

2) In Use

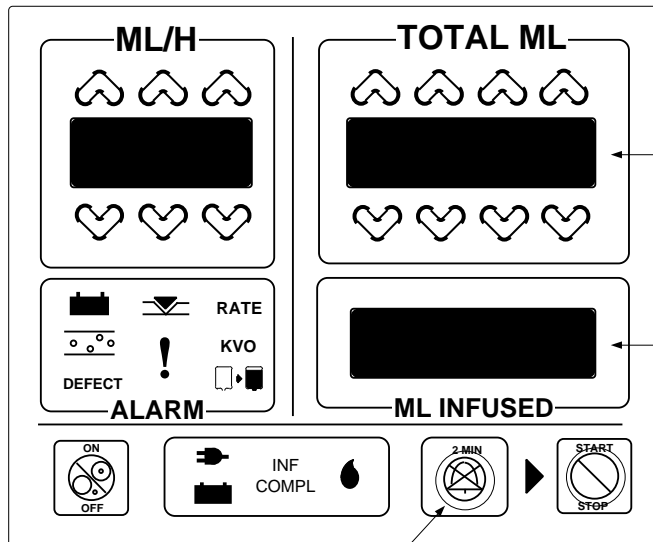

After Double Click '2MIN':

Pressure Limit:

Displays L600 default setting.
Can be adjusted up to desensitize or down to sensitize.
Remember to adjust down no lower than 40 above working pressure (e.g. working pr. 20 to 35 + 70 = 100).

Will display a **relative pressure** (=working pressure) between pump and patient.
e.g. P 20 to 35

Pressure

Recall of
- Pressure (mmHg)

Double Click
- Setting of the pressure limit in the TOTAL ML window

Condensed instructions for use

Volumed® μ VP5005

(Volumetric Pump)

- Connect 3101 P series Arcomed Administration set or Arcomed approved equivalent to fluid container.
- Fill the drip chamber 1/4 to 1/3 full.
- Release roller clamp and prime all air from the downstream line.
- Close roller clamp.
- Insert drip chamber into drop detector and secure using the retaining spring.
- Open pump door and depress stop flow lever.
- Correctly install the IV set into the pumping chamber and close door. Insert the tubing carefully in the air detector from top to bottom in the direction of the arrow.
- Connect infusion line to patient.
- Switch on unit (ON/OFF).
- Set required delivery rate.
- Set required total volume to be delivered (optional).
- Release roller clamp.
- Press START/STOP key to begin infusion.
- To switch off unit (power), press ON/OFF key and hold for about 1 second.

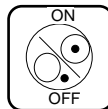
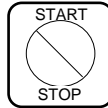
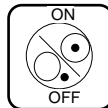

© 1995-2000 B. Braun